

Note: For the benefit of the students, specially the aspiring ones, the question of JEE(advanced), 2022 are also given in this booklet. Keeping the interest of students studying in class XI, the questions based on topics from class XI have been marked with ‘*’, which can be attempted as a test. For this test the time allocated in Physics, Chemistry & Mathematics are 25 minutes, 25 minutes and 25 minutes respectively.

FIITJEE

SOLUTIONS TO JEE (ADVANCED) – 2022

(Paper–1)

MATHEMATICS

SECTION 1 (Maximum Marks: 24)

- This section contains **EIGHT (08)** questions.
- The answer to each question is a **NUMERICAL VALUE**.
- For each question, enter the correct numerical values of the answer using the mouse and the on–screen virtual numerical keypad in the place designated to enter the answer. If the numerical value has more than two decimal places, **truncate/round–off** the value to **TWO** decimal places.
- Answer to each question will be evaluated according to the following marking scheme:
Full Marks : +3 **ONLY** if the correct numerical values is entered;
Zero Marks : 0 In all other cases.

*Q.1. Considering only the principal values of the inverse trigonometric functions, the value of

$$\frac{3}{2} \cos^{-1} \sqrt{\frac{2}{2+\pi^2}} + \frac{1}{4} \sin^{-1} \frac{2\sqrt{2}\pi}{2+\pi^2} + \tan^{-1} \frac{\sqrt{2}}{\pi}$$

is _____.

Q.2. Let α be a positive real number. Let $f : R \rightarrow R$ and $g : (\alpha, \infty) \rightarrow R$ be the functions defined by

$$f(x) = \sin\left(\frac{\pi x}{12}\right) \text{ and } g(x) = \frac{2 \log_e(\sqrt{x} - \sqrt{\alpha})}{\log_e(e^{\sqrt{x}} - e^{\sqrt{\alpha}})}.$$

Then the value of $\lim_{x \rightarrow \alpha^+} f(g(x))$ is _____.

Q.3. In a study about a pandemic, data of 900 persons was collected. It was found that
 190 persons had symptom of fever,
 220 persons had symptom of cough,
 220 persons had symptom of breathing problem,
 330 persons had symptom of fever or cough or both,
 350 persons had symptom of cough or breathing problem or both,
 340 persons had symptom of fever or breathing problem or both,
 30 persons had all three symptoms (fever, cough and breathing problem).
 If a person is chosen randomly from these 900 persons, then the probability that the person has at most one symptom is _____.

*Q.4. Let z be a complex number with non–zero imaginary part. If $\frac{2+3z+4z^2}{2-3z+4z^2}$ is a real number, then the value of $|z|^2$ is _____.

- *Q.5. Let \bar{z} denote the complex conjugate of a complex number z and let $i = \sqrt{-1}$. In the set of complex numbers, the number of distinct roots of the equation $\bar{z} - z^2 = i(\bar{z} + z^2)$ is _____.
- *Q.6. Let l_1, l_2, \dots, l_{100} be consecutive terms of an arithmetic with common difference d_1 , and let w_1, w_2, \dots, w_{100} be consecutive terms of another arithmetic progression with common difference d_2 , where $d_1 d_2 = 10$. For each $i = 1, 2, \dots, 100$, let R_i be a rectangle with length l_i , width w_i and area A_i . If $A_{51} - A_{50} = 1000$, then the value of $A_{100} - A_{90}$ is _____.
- *Q.7. The number of 4-digit integers in the closed interval $[2022, 4482]$ formed by using the digits 0, 2, 3, 4, 6, 7 is _____.
- *Q.8. Let ABC be the triangle with $AB = 1$, $AC = 3$ and $\angle BAC = \frac{\pi}{2}$. If a circle of radius $r > 0$ touches the sides AB, AC and also touches internally the Circumcircle of the triangle ABC , then the value of r is _____.

SECTION 2 (Maximum Marks: 24)

- This section contains **SIX (06)** questions.
- Each questions has **FOUR** options (A), (B), (C) and (D). **ONE OR MORE THAN ONE** of these four option(s) is(are) correct answer(s).
- For each question, choose the option(s) corresponding to (all) the correct answer(s).
- Answer to each question will be evaluated according to the following marking scheme:
Full Marks : +4 **ONLY** if (all) the correct option(s) is(are) chosen;
Partial Marks : +3 If all the four options are correct but **ONLY** three options are chosen;
Partial Marks : +2 If three or more options are correct but **ONLY** two options are chosen, both of which are correct;
Partial Marks : +1 If two or more options are correct but **ONLY** one option is chosen and it is a correct option;
Zero Marks : 0 If none of these of the options is chosen (i.e. the question is unanswered);
Negative Marks : -2 In all other cases.

Q.9. Consider the equation $\int_1^e \frac{(\log_e x)^{\frac{1}{2}}}{x \left(a - (\log_e x)^{\frac{3}{2}} \right)^2} dx = 1$, $a \in (-\infty, 0) \cup (1, \infty)$.

Which of the following statements is/are TRUE?

- (A) No a satisfies the above equation
 (B) An integer a satisfies the above equation
 (C) An irrational number a satisfies the above equation
 (D) More than one a satisfy the above equation
- *Q.10. Let a_1, a_2, a_3, \dots be an arithmetic progression with $a_1 = 7$ and common difference 8. Let T_1, T_2, T_3, \dots be such that $T_1 = 3$ and $T_{n+1} - T_n = a_n$ for $n \geq 1$. Then, which of the following is/are TRUE?
- (A) $T_{20} = 1604$ (B) $\sum_{k=1}^{20} T_k = 10510$
 (C) $T_{30} = 3454$ (D) $\sum_{k=1}^{30} T_k = 35610$

Q.11. Let P_1 and P_2 be two planes given by $P_1 : 10x + 15y + 12z - 60 = 0$, $P_2 : -2x + 5y + 4z - 20 = 0$. Which of the following straight lines can be an edge of some tetrahedron whose two faces lie on P_1 and P_2 ?

(A) $\frac{x-1}{0} = \frac{y-1}{0} = \frac{z-1}{5}$

(B) $\frac{x-6}{-5} = \frac{y}{2} = \frac{z}{3}$

(C) $\frac{x}{-2} = \frac{y-4}{5} = \frac{z}{4}$

(D) $\frac{x}{1} = \frac{y-4}{-2} = \frac{z}{3}$

Q.12. Let S be the reflection of a point Q with respect to the plane given by $\vec{r} = -(t+p)\hat{i} + t\hat{j} + (1+p)\hat{k}$ where t, p are real parameters and $\hat{i}, \hat{j}, \hat{k}$ are the unit vectors along the three positive coordinate axes. If the position vectors of Q and S are $10\hat{i} + 15\hat{j} + 20\hat{k}$ and $\alpha\hat{i} + \beta\hat{j} + \gamma\hat{k}$ respectively, then which of the following is/are TRUE?

(A) $3(\alpha + \beta) = -101$

(B) $3(\beta + \gamma) = -71$

(C) $3(\gamma + \alpha) = -86$

(D) $3(\alpha + \beta + \gamma) = -121$

*Q.13. Consider the parabola $y^2 = 4x$. Let S be the focus of the parabola. A pair of tangents drawn to the parabola from the point $P = (-2, 1)$ meet the parabola at P_1 and P_2 . Let Q_1 and Q_2 be points on the lines SP_1 and SP_2 respectively such that PQ_1 is perpendicular to SP_1 and PQ_2 is perpendicular to SP_2 . Then, which of the following is/are TRUE?

(A) $SQ_1 = 2$

(B) $Q_1Q_2 = \frac{3\sqrt{10}}{5}$

(C) $PQ_1 = 3$

(D) $SQ_2 = 1$

Q.14. Let $|M|$ denote the determinant of a square matrix M . Let $g : \left[0, \frac{\pi}{2}\right] \rightarrow \mathbb{R}$ be the function defined by

$$g(\theta) = \sqrt{f(\theta)-1} + \sqrt{f\left(\frac{\pi}{2}-\theta\right)-1}$$

$$\text{where } f(\theta) = \frac{1}{2} \begin{vmatrix} 1 & \sin \theta & 1 \\ -\sin \theta & 1 & \sin \theta \\ -1 & -\sin \theta & 1 \end{vmatrix} + \begin{vmatrix} \sin \pi & \cos\left(\theta + \frac{\pi}{4}\right) & \tan\left(\theta - \frac{\pi}{4}\right) \\ \sin\left(\theta - \frac{\pi}{4}\right) & -\cos \frac{\pi}{2} & \log_e\left(\frac{4}{\pi}\right) \\ \cot\left(\theta + \frac{\pi}{4}\right) & \log_e\left(\frac{\pi}{4}\right) & \tan \pi \end{vmatrix}.$$

Let $p(x)$ be a quadratic polynomial whose roots are the maximum and minimum values of the function $g(\theta)$ and $p(2) = 2 - \sqrt{2}$. Then, which of the following is/are TRUE?

(A) $p\left(\frac{3+\sqrt{2}}{4}\right) < 0$

(B) $p\left(\frac{1+3\sqrt{2}}{4}\right) > 0$

(C) $p\left(\frac{5\sqrt{2}-1}{4}\right) > 0$

(D) $p\left(\frac{5-\sqrt{2}}{4}\right) < 0$

SECTION 3 (Maximum Marks: 12)

- This section contains **FOUR (04)** Matching List Sets.
- Each set has **ONE** Multiple Choice Question.
- Each set has **TWO** lists: **List-I** and **List-II**.
- List-I** has **Four** entries (I), (II), (III) and (IV) and **List-II** has **Five** entries (P), (Q), (R), (S) and (T).
- FOUR** options are given in each Multiple Choice Question based on **List-I** and **List-II** and **ONLY ONE** of these four options satisfies the condition asked in the Multiple Choice Question.
- Answer to each question will be evaluated according to the following marking scheme:
Full Marks : +3 **ONLY** if the option corresponding to the correct combination is chosen;
Zero Marks : 0 If none of these of the options is chosen (i.e. the question is unanswered);
Negative Marks : -1 In all other cases.

*Q.15. Consider the following lists:

List-I		List-II	
(I)	$\left\{x \in \left[-\frac{2\pi}{3}, \frac{2\pi}{3}\right] : \cos x + \sin x = 1\right\}$	(P)	has two elements
(II)	$\left\{x \in \left[-\frac{5\pi}{18}, \frac{5\pi}{18}\right] : \sqrt{3} \tan 3x = 1\right\}$	(Q)	has three elements
(III)	$\left\{x \in \left[-\frac{6\pi}{5}, \frac{6\pi}{5}\right] : 2 \cos(2x) = \sqrt{3}\right\}$	(R)	has four elements
(IV)	$\left\{x \in \left[-\frac{7\pi}{4}, \frac{7\pi}{4}\right] : \sin x - \cos x = 1\right\}$	(S)	has five elements
		(T)	has six elements

The correct option is:

- (A) (I) → (P); (II) → (S); (III) → (P); (IV) → (S)
 (B) (I) → (P); (II) → (P); (III) → (T); (IV) → (R)
 (C) (I) → (Q); (II) → (P); (III) → (T); (IV) → (S)
 (D) (I) → (Q); (II) → (S); (III) → (P); (IV) → (R)

Q.16. Two players, P_1 and P_2 , play a game against each other. In every round of the game, each player rolls a fair die once, where the six faces of the die have six distinct numbers. Let x and y denote the readings on the die rolled by P_1 and P_2 , respectively. If $x > y$, then P_1 scores 5 points and P_2 scores 0 points. If $x = y$, then each player scores 2 points. If $x < y$, then P_1 scores 0 point and P_2 scores 5 points. Let X_i and Y_i be the total scores of P_1 and P_2 , respectively, after playing the i^{th} round.

List-I		List-II	
(I)	Probability of $(X_2 \geq Y_2)$ is	(P)	$\frac{3}{8}$
(II)	Probability of $(X_2 > Y_2)$ is	(Q)	$\frac{11}{16}$
(III)	Probability of $(X_3 = Y_3)$ is	(R)	$\frac{5}{16}$
(IV)	Probability of $(X_3 > Y_3)$ is	(S)	$\frac{355}{864}$
		(T)	$\frac{77}{432}$

The correct option is:

- (A) (I) → (Q); (II) → (R); (III) → (T); (IV) → (S) (B) (I) → (Q); (II) → (R); (III) → (T); (IV) → (T)
 (C) (I) → (P); (II) → (R); (III) → (Q); (IV) → (S) (D) (I) → (P); (II) → (R); (III) → (Q); (IV) → (T)

- Q.17. Let p, q, r be nonzero real numbers that are, respectively, the $10^{\text{th}}, 100^{\text{th}}$ and 1000^{th} terms of a harmonic progression. Consider the system of linear equation

$$\begin{aligned}x + y + z &= 1 \\10x + 100y + 1000z &= 0 \\qrx + pry + pqz &= 0\end{aligned}$$

List-I		List-II	
(I)	If $\frac{q}{r} = 10$, then the system of linear equations has	(P)	$x = 0, y = \frac{10}{9}, z = -\frac{1}{9}$
(II)	If $\frac{p}{r} \neq 100$, then the system of linear equations has	(Q)	$x = \frac{10}{9}, y = -\frac{1}{9}, z = 0$ as a solution
(III)	If $\frac{p}{q} \neq 10$, then the system of linear equation has	(R)	infinitely many solutions
(IV)	If $\frac{p}{q} = 10$, then the system of linear equations has	(S)	no solution
		(T)	at least one solution

The correct option is:

- (A) (I) \rightarrow (T); (II) \rightarrow (R); (III) \rightarrow (S); (IV) \rightarrow (T)
 (B) (I) \rightarrow (Q); (II) \rightarrow (S); (III) \rightarrow (S); (IV) \rightarrow (R)
 (C) (I) \rightarrow (Q); (II) \rightarrow (R); (III) \rightarrow (P); (IV) \rightarrow (R)
 (D) (I) \rightarrow (T); (II) \rightarrow (S); (III) \rightarrow (P); (IV) \rightarrow (T)

- *Q.18 Consider the ellipse $\frac{x^2}{4} + \frac{y^2}{3} = 1$. Let $H(\alpha, 0)$, $0 < \alpha < 2$, be a point. A straight line drawn through H parallel to y -axis crosses the ellipse and its auxiliary circle at points E and F respectively, in the first quadrant. The tangents to the ellipse at the point E intersects the positive x -axis at a point G . Suppose the straight line joining F and the origin makes an angle ϕ with the positive x -axis.

List-I		List-II	
(I)	If $\phi = \frac{\pi}{4}$, then the area of the triangle FGH is	(P)	$\frac{(\sqrt{3}-1)^4}{8}$
(II)	If $\phi = \frac{\pi}{3}$, then the area of the triangle FGH is	(Q)	1
(III)	If $\phi = \frac{\pi}{6}$, then the area of the triangle FGH is	(R)	$\frac{3}{4}$
(IV)	If $\phi = \frac{\pi}{12}$, then the area of the triangle FGH is	(S)	$\frac{1}{2\sqrt{3}}$
		(T)	$\frac{3\sqrt{3}}{2}$

The correct option is:

- (A) (I) \rightarrow (R); (II) \rightarrow (S); (III) \rightarrow (Q); (IV) \rightarrow (P)
 (B) (I) \rightarrow (R); (II) \rightarrow (T); (III) \rightarrow (S); (IV) \rightarrow (P)
 (C) (I) \rightarrow (Q); (II) \rightarrow (T); (III) \rightarrow (S); (IV) \rightarrow (P)
 (D) (I) \rightarrow (Q); (II) \rightarrow (S); (III) \rightarrow (Q); (IV) \rightarrow (P)

PART II: PHYSICS

SECTION 1 (Maximum Marks: 24)

- This section contains **EIGHT (08)** questions.
- The answer to each question is a **NUMERICAL VALUE**.
- For each question, enter the correct numerical values of the answer using the mouse and the on-screen virtual numerical keypad in the place designated to enter the answer. If the numerical value has more than two decimal places, **truncate/round-off** the value to **TWO** decimal places.
- Answer to each question will be evaluated according to the following marking scheme:
Full Marks : +3 **ONLY** if the correct numerical values is entered;
Zero Marks : 0 In all other cases.

- *Q.1 Two spherical stars A and B have densities ρ_A and ρ_B , respectively. A and B have the same radius, and their masses M_A and M_B are related by $M_B = 2 M_A$. Due to an interaction process, star A loses some of its mass, so that its radius is halved, while its spherical shape is retained, and its density remains ρ_A . The entire mass lost by A is deposited as a thick spherical shell on B with the density of the shell being ρ_A . If v_A and v_B are the escape velocities from A and B after the interaction process, the ratio $\frac{v_B}{v_A} = \sqrt{\frac{10n}{15^{1/3}}}$. The value of n is _____.
- Q.2 The minimum kinetic energy needed by an alpha particle to cause the nuclear reaction ${}^{16}_7\text{N} + {}^4_2\text{He} \rightarrow {}^1_1\text{H} + {}^{19}_8\text{O}$ in a laboratory frame is n (in MeV). Assume that ${}^{16}_7\text{N}$ is at rest in the laboratory frame. The masses of ${}^{16}_7\text{N}$, ${}^4_2\text{He}$, ${}^1_1\text{H}$ and ${}^{19}_8\text{O}$ can be taken to be 16.006 u, 4.003 u, 1.008 u and 19.003 u, respectively, where 1 u = 930 MeVc⁻². The value of n is _____.

- Q3. In the following circuit $C_1 = 12 \mu\text{F}$, $C_2 = C_3 = 4 \mu\text{F}$ and $C_4 = C_5 = 2 \mu\text{F}$. The charge stored in C_3 is _____ μC .

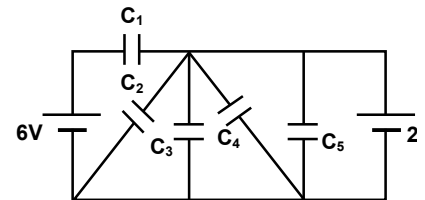

- Q.4 A rod of length 2 cm makes an angle $\frac{2\pi}{3}$ rad with the principal axis of a thin convex lens. The lens has a focal length of 10 cm and is placed at a distance of $\frac{40}{3}$ cm from the object as shown in the figure. The height of the image is $\frac{30\sqrt{3}}{13}$ and the angle made by it with respect to the principal axis is α rad. The value of α is $\frac{\pi}{n}$ rad, where n is _____.

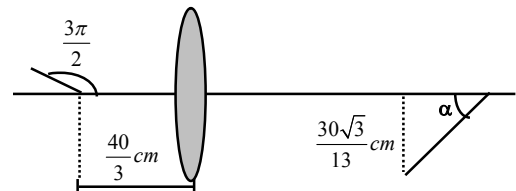

- *Q.5 At time $t=0$, a disk of radius 1 m starts to roll without slipping on a horizontal plane with an angular acceleration of $\alpha = \frac{2}{3} \text{ rad s}^{-2}$. A small stone is stuck to the disk. At $t = 0$, it is at the contact point of the disk and the plane. Later, at time $t = \sqrt{\pi}$ s, the stone detaches itself and flies off tangentially from the disk. The maximum height (in m) reached by the stone measured from the plane is $\frac{1}{2} + \frac{x}{10}$. The value of x is _____ [Take $g = 10 \text{ ms}^{-2}$.]

- *Q.6 A solid sphere of mass 1 kg and radius 1 m rolls without slipping on a fixed inclined plane with an angle of inclination $\theta = 30^\circ$ from the horizontal. Two forces of magnitude 1 N each, parallel to the incline, act on the sphere, both at distance $r = 0.5$ m from the center of the sphere, as shown in the figure. The acceleration of the sphere down the plane is _____ ms^{-2} . (Take $g = 10 \text{ ms}^{-2}$.)

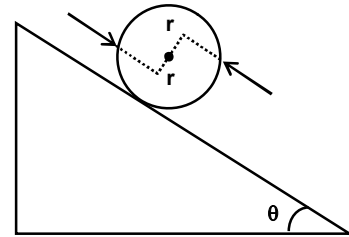

- Q.7 Consider an LC circuit, with inductance $L = 0.1$ H and capacitance $C = 10^{-3}$ F, kept on a plane. The area of the circuit is 1 m^2 . It is placed in a constant magnetic field of strength B_0 which is perpendicular to the plane of the circuit. At time $t = 0$, the magnetic field strength starts increasing linearly as $B = B_0 + \beta t$ with $\beta = 0.04 \text{ Ts}^{-1}$. The maximum magnitude of the current in the circuit is _____ mA.
- *Q.8 A projectile is fired from horizontal ground with speed v and projection angle θ . When the acceleration due to gravity is g , the range of the projectile is d . If at the highest point in its trajectory, the projectile enters a different region where the effective acceleration due to gravity is $g' = \frac{g}{0.81}$, then the new range is $d' = nd$. The value of n is _____.

SECTION 2 (Maximum Marks: 24)

- This section contains **SIX (06)** questions.
- Each questions has **FOUR** options (A), (B), (C) and (D). **ONE OR MORE THAN ONE** of these four option(s) is(are) correct answer(s).
- For each question, choose the option(s) corresponding to (all) the correct answer(s).
- Answer to each question will be evaluated according to the following marking scheme:

Full Marks : +4 **ONLY** if (all) the correct option(s) is(are) chosen;

Partial Marks : +3 If all the four options are correct but **ONLY** three options are chosen;

Partial Marks : +2 If three or more options are correct but **ONLY** two options are chosen, both of which are correct;

Partial Marks : +1 If two or more options are correct but **ONLY** one option is chosen and it is a correct option;

Zero Marks : 0 If none of the options is chosen (i.e. the question is unanswered);

Negative Marks : -2 In all other cases.

- Q.9 A medium having dielectric constant $K > 1$ fills the space between the plates of a parallel plate capacitor. The plates have large area, and the distance between them is d . The capacitor is connected to a battery of

voltage V , as shown in Figure (a). Now, both the plates are moved by a distance $d/2$ of from their original positions, as shown in Figure (b).

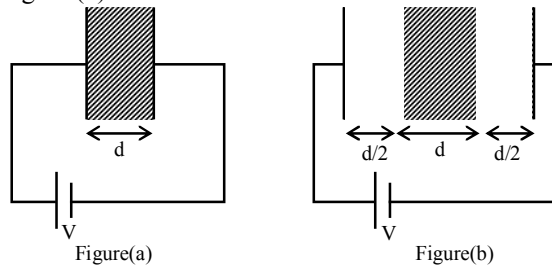

In the process of going from the configuration depicted in Figure (a) to that in Figure (b), which of the following statement(s) is(are) correct?

- (A) The electric field inside the dielectric material is reduced by a factor of $2K$.
 (B) The capacitance is decreased by a factor of $\frac{1}{K+1}$.
 (C) The voltage between the capacitor plates is increased by a factor of $(K+1)$.
 (D) The work done in the process **DOES NOT** depend on the presence of the dielectric material.

- Q.10 The figure shows a circuit having eight resistances of 1Ω each, labelled R_1 to R_8 , and two ideal batteries with voltages $\varepsilon_1 = 12\text{ V}$ and $\varepsilon_2 = 6\text{ V}$.

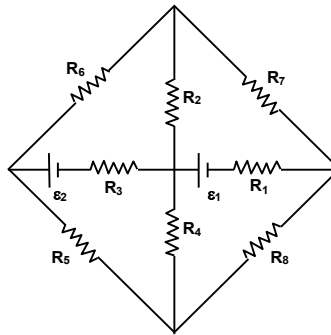

Which of the following statement(s) is(are) correct?

- (A) The magnitude of current flowing through R_1 is 7.2 A .
 (B) The magnitude of current flowing through R_2 is 1.2 A .
 (C) The magnitude of current flowing through R_3 is 4.8 A .
 (D) The magnitude of current flowing through R_5 is 2.4 A .
- *Q.11 An ideal gas of density $\rho = 0.2\text{ kg m}^{-3}$ enters a chimney of height h at the rate of $\alpha = 0.8\text{ kg s}^{-1}$ from its lower end, and escapes through the upper end as shown in the figure. The cross-sectional area of the lower end is $A_1 = 0.1\text{ m}^2$ and the upper end is $A_2 = 0.4\text{ m}^2$. The pressure and the temperature of the gas at the lower end are 600 Pa and 300 K , respectively, while its temperature at the upper end is 150 K . The chimney is heat insulated so that the gas undergoes adiabatic expansion. Take $g = 10\text{ ms}^{-2}$ and the ratio of specific heats of the gas $\gamma = 2$. Ignore atmospheric pressure.

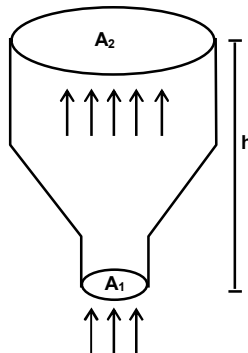

Which of the following statement(s) is(are) correct?

- (A) The pressure of the gas at the upper end of the chimney is 300 Pa.
 (B) The velocity of the gas at the lower end of the chimney is 40 ms^{-1} and at the upper end is 20 ms^{-1} .
 (C) The height of the chimney is 590m.
 (D) The density of the gas at the upper end is 0.05 kg m^{-3}

- Q.12 Three plane mirrors form an equilateral triangle with each side of length L . There is a small hole at a distance $l > 0$ from one of the corners as shown in the figure. A ray of light is passed through the hole at an angle θ and can only come out through the same hole. The cross section of the mirror configuration and the ray of light lie on the same plane.

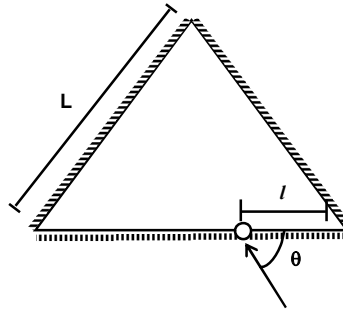

Which of the following statement(s) is(are) correct?

- (A) The ray of light will come out for $\theta = 30^\circ$, for $0 < l < L$.
 (B) There is an angle for $l = \frac{L}{2}$ at which the ray of light will come out after two reflections.
 (C) The ray of light will **NEVER** come out for $\theta = 60^\circ$, and $l = \frac{L}{3}$
 (D) The ray of light will come out for $\theta = 60^\circ$, and $0 < l < \frac{L}{2}$ after six reflections.

- Q.13 Six charges are placed around a regular hexagon of side length a as shown in the figure. Five of them have charge q , and the remaining one has charge x . The perpendicular from each charge to the nearest hexagon side passes through the center O of the hexagon and is bisected by the side.

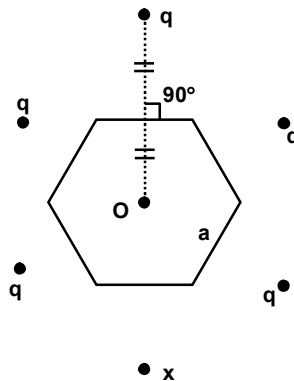

Which of the following statement(s) is(are) correct in SI units?

- (A) When $x = q$, the magnitude of the electric field at O is zero.
- (B) When $x = -q$, the magnitude of the electric field at O is $\frac{q}{6\pi\epsilon_0 a^2}$
- (C) When $x = 2q$, the potential at O is $\frac{7q}{4\sqrt{3}\pi\epsilon_0 a}$.
- (D) When $x = -3q$, the potential at O is $-\frac{3q}{4\sqrt{3}\pi\epsilon_0 a}$

Q.14 The binding energy of nucleons in a nucleus can be affected by the pairwise Coulomb repulsion. Assume that all nucleons are uniformly distributed inside the nucleus. Let the binding energy of a proton be E_b^p and the binding energy of a neutron be E_b^n in the nucleus. Which of the following statement(s) is(are) correct?

- (A) $E_b^p - E_b^n$ is proportional to $Z(Z-1)$ where Z is the atomic number of the nucleus.
- (B) $E_b^p - E_b^n$ is proportional to $A^{-\frac{1}{3}}$ where A is the mass number of the nucleus.
- (C) $E_b^p - E_b^n$ is positive.
- (D) E_b^p increases if the nucleus undergoes a beta decay emitting a positron.

SECTION 3 (Maximum Marks: 12)

- This section contains **FOUR (04)** Matching List Sets.
- Each set has **ONE** Multiple Choice Question.
- Each set has **TWO** lists: **List-I** and **List-II**.
- **List-I** has **Four** entries (I), (II), (III) and (IV) and **List-II** has **Five** entries (P), (Q), (R), (S) and (T).
- **FOUR** options are given in each Multiple Choice Question based on **List-I** and **List-II** and **ONLY ONE** of these four options satisfies the condition asked in the Multiple Choice Question.
- Answer to each question will be evaluated according to the following marking scheme:
Full Marks : +3 **ONLY** if the option corresponding to the correct combination is chosen;
Zero Marks : 0 If none of the options is chosen (i.e. the question is unanswered);
Negative Marks : -1 In all other cases.

- Q.15 A smaller circular loop of area A and resistance R is fixed on a horizontal xy -plane with the center of the loop always on the axis \hat{n} of a long solenoid. The solenoid has m turns per unit length and carries current I counterclockwise as shown in the figure. The magnetic field due to the solenoid is in \hat{n} direction. List-I gives time dependences of \hat{n} in terms of a constant angular frequency ω . List-II gives the torques experienced by the circular loop at time $t = \frac{\pi}{6\omega}$. Let $\alpha = \frac{A^2 \mu_0^2 m^2 I^2 \omega}{2R}$.

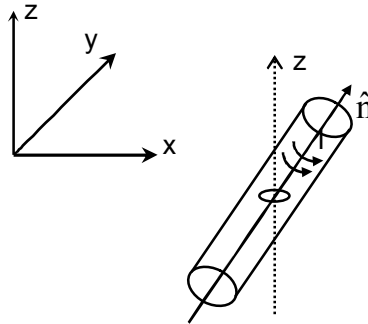

List -I		List -II	
(I)	$\frac{1}{\sqrt{2}}(\sin \omega t \hat{j} + \cos \omega t \hat{k})$	(P)	0
(II)	$\frac{1}{\sqrt{2}}(\sin \omega t \hat{i} + \cos \omega t \hat{j})$	(Q)	$-\frac{\alpha}{4} \hat{i}$
(III)	$\frac{1}{\sqrt{2}}(\sin \omega t \hat{i} + \cos \omega t \hat{k})$	(R)	$\frac{3\alpha}{4} \hat{i}$
(IV)	$\frac{1}{\sqrt{2}}(\cos \omega t \hat{j} + \sin \omega t \hat{k})$	(S)	$\frac{\alpha}{4} \hat{j}$
		(T)	$-\frac{3\alpha}{4} \hat{i}$

Which one of the following options is correct ?

- (A) I \rightarrow Q, II \rightarrow P, III \rightarrow S, IV \rightarrow T (B) I \rightarrow S, II \rightarrow T, III \rightarrow Q, IV \rightarrow P
 (C) I \rightarrow Q, II \rightarrow P, III \rightarrow S, IV \rightarrow R (D) I \rightarrow T, II \rightarrow Q, III \rightarrow P, IV \rightarrow R

*Q.16 List I describes four systems, each with two particles A and B in relative motion as shown in figures. List II gives possible magnitudes of their relative velocities (in m s^{-1}) at time $t = \frac{\pi}{3}$ s.

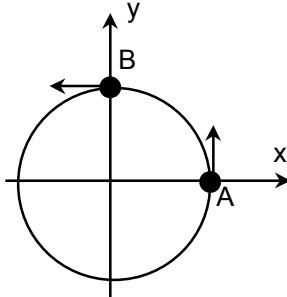
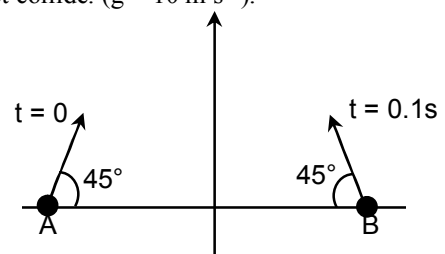
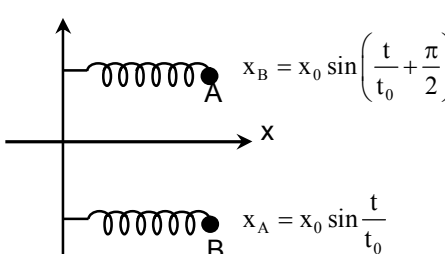
List - I		List - II	
(I)	<p>A and B are moving on a horizontal circle of radius 1 m with uniform angular speed $\omega = 1 \text{ rad s}^{-1}$. The initial angular positions of A and B at time $t = 0$ are $\theta = 0$ and $\theta = \frac{\pi}{2}$, respectively.</p> 	(P)	$\frac{\sqrt{3}+1}{2}$
(II)	<p>Projectiles A and B are fired (in the same vertical plane) at $t = 0$ and $t = 0.1 \text{ s}$ respectively, with the same speed $v = \frac{5\pi}{\sqrt{2}} \text{ m s}^{-1}$ and at 45° from the horizontal plane. The initial separation between A and B is large enough so that they do not collide. ($g = 10 \text{ m s}^{-2}$).</p> 	(Q)	$\frac{(\sqrt{3}-1)}{\sqrt{2}}$
(III)	<p>Two harmonic oscillators A and B moving in the x direction according to $x_A = x_0 \sin \frac{t}{t_0}$ and $x_B = x_0 \sin \left(\frac{t}{t_0} + \frac{\pi}{2} \right)$ respectively, starting from $t = 0$. Take $x_0 = 1 \text{ m}$, $t_0 = 1 \text{ s}$.</p> 	(R)	$\sqrt{10}$

(IV)	Particle A is rotating in a horizontal circular path of radius 1 m on the xy plane, with constant angular speed $\omega = 1 \text{ rad s}^{-1}$. Particle B is moving up at a constant speed 3 m s^{-1} in the vertical direction as shown in the figure. (Ignore gravity.)	(S)	$\sqrt{2}$
		(T)	$\sqrt{25\pi^2 + 1}$

Which one of the following options is correct ?

- (A) I \rightarrow R, II \rightarrow T, III \rightarrow P, IV \rightarrow S
 (B) I \rightarrow S, II \rightarrow P, III \rightarrow Q, IV \rightarrow R
 (C) I \rightarrow S, II \rightarrow T, III \rightarrow P, IV \rightarrow R
 (D) I \rightarrow T, II \rightarrow P, III \rightarrow R, IV \rightarrow S

*Q.17 List I describes thermodynamic processes in four different systems. List II gives the magnitudes (either exactly or as a close approximation) of possible changes in the internal energy of the system due to the process.

List -I		List -II	
(I)	10^{-3} kg of water at 100°C is converted to steam at the same temperature, at a pressure of 10^5 Pa. The volume of the system changes from 10^{-6} m^3 to 10^{-3} m^3 in the process. Latent heat of water = 2250 kJ/kg .	(P)	2 kJ
(II)	0.2 moles of a rigid diatomic ideal gas with volume V at temperature 500 K undergoes an isobaric expansion to volume $3V$. Assume $R = 8.0 \text{ J mol}^{-1} \text{ K}^{-1}$.	(Q)	7 kJ
(III)	One mole of a monatomic ideal gas is compressed adiabatically from volume $V = \frac{1}{3} \text{ m}^3$ and pressure 2 kPa to volume $\frac{V}{8}$.	(R)	4 kJ
(IV)	Three moles of a diatomic ideal gas whose molecules can vibrate, is given 9 kJ of heat and undergoes isobaric expansion.	(S)	5 kJ
		(T)	3 kJ

Which one of the following options is correct ?

- (A) I \rightarrow T, II \rightarrow R, III \rightarrow S, IV \rightarrow Q (B) I \rightarrow S, II \rightarrow P, III \rightarrow T, IV \rightarrow P
 (C) I \rightarrow P, II \rightarrow R, III \rightarrow T, IV \rightarrow Q (D) I \rightarrow Q, II \rightarrow R, III \rightarrow S, IV \rightarrow T

- Q.18 List I contains four combinations of two lenses (1 and 2) whose focal lengths (in cm) are indicated in the figures. In all cases, the object is placed 20 cm from the first lens on the left, and the distance between the two lenses is 5 cm. List II contains the positions of the final images.

List -I		List -II	
(I)	<p>$f = +10$ $+15$</p>	(P)	Final image is formed at 7.5 cm on the right side of lens 2.
(II)	<p>$f = +10$ $+10$</p>	(Q)	Final image is formed at 60.0 cm on the right side of lens 2.
(III)	<p>$f = +10$ -20</p>	(R)	Final image is formed at 30.0 cm on the left side of lens 2.
(IV)	<p>$f = -20$ $+10$</p>	(S)	Final image is formed at 6.0 cm on the right side of lens 2.
		(T)	Final image is formed at 30.0 cm on the right side of lens 2.

Which one of the following options is correct?

- (A) (I) → P; (II) → R; (III) → Q; (IV) → T (B) (I) → Q; (II) → P; (III) → T; (IV) → S
 (C) (I) → P; (II) → T; (III) → R; (IV) → Q (D) (I) → T; (II) → S; (III) → Q; (IV) → R

PART III: CHEMISTRY

SECTION 1 (Maximum Marks: 24)

- This section contains **EIGHT (08)** questions.
- The answer to each question is a **NUMERICAL VALUE**.
- For each question, enter the correct numerical value of the answer using the mouse and the onscreen virtual numeric keypad in the place designated to enter the answer. If the numerical value has more than two decimal places, **truncate/round off** the value to **TWO** decimal places.
- Answer to each question will be evaluated according to the following marking scheme:
Full Marks : +3 **ONLY** if the correct numerical value is entered;
Zero Marks : 0 In all other cases.

- *Q1. 2 mol of Hg(g) is combusted in a fixed volume bomb calorimeter with excess of O₂ at 298 K and 1 atm into HgO(s). During the reaction, temperature increases from 298.0 K to 312.8 K. If heat capacity of the bomb calorimeter and enthalpy of formation of Hg(g) are 20.00 kJ K⁻¹ and 61.32 kJ mol⁻¹ at 298 K, respectively, the calculated standard molar enthalpy of formation of HgO(s) at 298 K is X kJ mol⁻¹. The value of |X| is _____.

[Given: Gas constant R = 8.3 J K⁻¹ mol⁻¹]

- Q2. The reduction potential (E⁰, in V) of MnO₄⁻(aq)/Mn(s) is _____.

[Given : E⁰_{(MnO₄⁻(aq)/MnO₂(s)) = 1.68V; E⁰_{(MnO₂(s)/Mn²⁺(aq)) = 1.21V; E⁰_{(Mn²⁺(aq)/Mn(s)) = -1.03V]}}}

- *Q3. A solution is prepared by mixing 0.01 mol each of H₂CO₃, NaHCO₃, Na₂CO₃, and NaOH in 100 mL of water. pH of the resulting solution is _____.

[Given: pK_{a1} and pK_{a2} of H₂CO₃ are 6.37 and 10.32, respectively; log 2 = 0.30]

- *Q4. The treatment of an aqueous solution of 3.74 g of Cu(NO₃)₂ with excess KI results in a brown solution along with the formation of a precipitate. Passing H₂S through this brown solution gives another precipitate X. The amount of X (in g) is _____.

[Given: Atomic mass of H = 1, N = 14, O = 16, S = 32, K = 39, Cu = 63, I = 127]

- *Q5. Dissolving 1.24 g of white phosphorous in boiling NaOH solution in an inert atmosphere gives a gas Q. The amount of CuSO₄ (in g) required to completely consume the gas Q is _____.

[Given: Atomic mass of H = 1, O = 16, Na = 23, P = 31, S = 32, Cu = 63]

- Q6. Consider the following reaction.

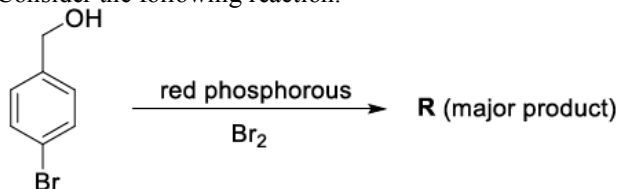

On estimation of bromine in 1.00 g of R using Carius method, the amount of AgBr formed (in g) is _____.

[Given: Atomic mass of H = 1, C = 12, O = 16, P = 31, Br = 80, Ag = 108].

Q7. The weight percentage of hydrogen in **Q**, formed in the following reaction sequence, is _____.

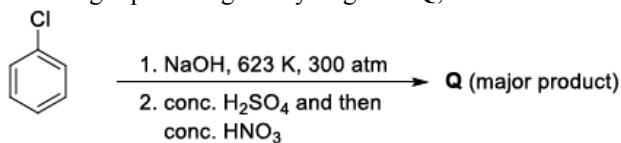

[Given: Atomic mass of H = 1, C = 12, N = 14, O = 16, S = 32, Cl = 35]

Q8. If the reaction sequence given below is carried out with 15 moles of acetylene, the amount of the product **D** formed (in g) is _____.

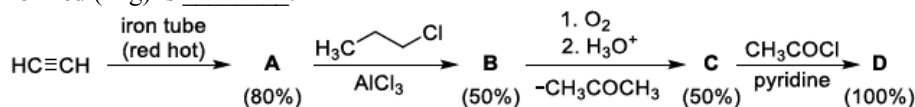

The yields of **A**, **B**, **C** and **D** are given in parentheses.

[Given: Atomic mass of H = 1, C = 12, O = 16, Cl = 35]

SECTION 2 (Maximum Marks: 24)

- This section contains **SIX (06)** questions.
 - Each question has **FOUR** options (A), (B), (C) and (D). **ONE OR MORE THAN ONE** of these four option(s) is (are) correct answer(s).
 - For each question, choose the option(s) corresponding to (all) the correct answer(s).
 - Answer to each question will be evaluated according to the following marking scheme:
- | | | | |
|-----------------------|---|----|--|
| <i>Full Mark</i> | : | +4 | If only (all) the correct option(s) is(are) chosen; |
| <i>Partial Marks</i> | : | +3 | If all the four options are correct but ONLY three options are chosen; |
| <i>Partial Marks</i> | : | +2 | If three or more options are correct but ONLY two options are chosen, both of which are correct; |
| <i>Partial Marks</i> | : | +1 | If two or more options are correct but ONLY one option is chosen and it is a correct option; |
| <i>Zero Marks</i> | : | 0 | If unanswered; |
| <i>Negative Marks</i> | : | -2 | In all other cases. |

- *Q9 For diatomic molecules, the correct statement(s) about the molecular orbitals formed by the overlap of two $2p_z$ orbitals is(are)
- (A) σ orbital has a total of two nodal planes
 (B) σ^* orbital has one node in the xz -plane containing the molecular axis.
 (C) π orbital has one node in the plane which is perpendicular to the molecular axis and goes through the center of the molecule.
 (D) π^* orbital has one node in the xy -plane containing the molecular axis.
- Q10. The correct option(s) related to adsorption process is (are)
- (A) Chemisorption results in unimolecular layer.
 (B) The enthalpy change during physisorption is in the range of 100 to 140 kJ mol^{-1}
 (C) Chemisorption is an endothermic process
 (D) Lowering the temperature favours physisorption process
- Q11. The electrochemical extraction of aluminum from bauxite ore involves
- (A) the reaction of Al_2O_3 with coke (C) at a temperature $> 2500^\circ\text{C}$.
 (B) the neutralization of aluminate solution by passing CO_2 gas to precipitate hydrated alumina ($\text{Al}_2\text{O}_3 \cdot 3\text{H}_2\text{O}$).
 (C) the dissolution of Al_2O_3 in hot aqueous NaOH.
 (D) the electrolysis of Al_2O_3 mixed with Na_3AlF_6 to give Al and CO_2 .

SECTION 3 (Maximum Marks: 12)

- This section contains **FOUR (04)** Matching List Sets.
- Each set has **ONE** Multiple Choice Question.
- Each set has **TWO** lists: **List I** and **List II**.
- **List I** has **Four** entries (I), (II), (III) and (IV) and **List II** has **Five** entries (P), (Q), (R), (S) and (T).
- **FOUR** options are given in each Multiple Choice Question based on **List I** and **List II** and **ONLY ONE** of these four options satisfies the condition asked in the Multiple Choice Question.
- Answer to each question will be evaluated according to the following marking scheme:
Full Marks : +3 **ONLY** if the option corresponding to the correct combination is chosen;
Zero Marks : 0 if none of the options is chosen (i.e. the question is unanswered);
Negative Marks : -1 in all other cases.

*Q15. Match the rate expressions in LIST-I for the decomposition of X with the corresponding profiles provided in LIST-II. X_s and k are constants having appropriate units.

LIST-I

(I)
$$\text{rate} = \frac{k[X]}{X_s + [X]}$$
 under all possible initial concentrations of X

(II)
$$\text{rate} = \frac{k[X]}{X_s + [X]}$$
 where initial concentrations of X are much less than X_s

(III)
$$\text{rate} = \frac{k[X]}{X_s + [X]}$$
 where initial concentrations of X are much higher than X_s

(IV)
$$\text{rate} = \frac{k[X]^2}{X_s + [X]}$$
 where initial concentration of X is much higher than X_s

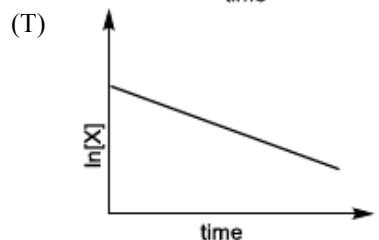
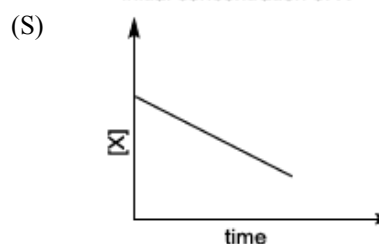
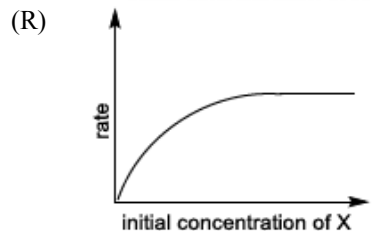
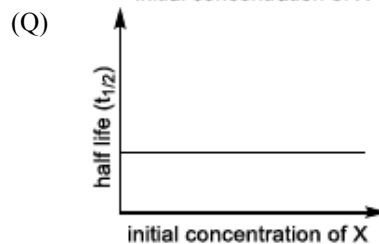
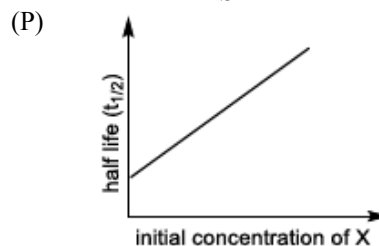
LIST-II

- (A) I → P; II → Q; III → S; IV → T
 (C) I → P; II → Q; III → Q; IV → R

- (B) I → R; II → S; III → S; IV → T
 (D) I → R; II → S; III → Q; IV → R

*Q16. LIST-I contains compounds and LIST-II contains reactions.

LIST-I	LIST-II
(I) H_2O_2	(P) $\text{Mg}(\text{HCO}_3)_2 + \text{Ca}(\text{OH})_2 \rightarrow$
(II) $\text{Mg}(\text{OH})_2$	(Q) $\text{BaO}_2 + \text{H}_2\text{SO}_4 \rightarrow$
(III) BaCl_2	(R) $\text{Ca}(\text{OH})_2 + \text{MgCl}_2 \rightarrow$
(IV) CaCO_3	(S) $\text{BaO}_2 + \text{HCl} \rightarrow$
	(T) $\text{Ca}(\text{HCO}_3)_2 + \text{Ca}(\text{OH})_2 \rightarrow$

Match each compound in LIST-I with its formation reaction(s) in LIST-II, and choose the correct option

- (A) I \rightarrow Q; II \rightarrow P; III \rightarrow S; IV \rightarrow R
 (B) I \rightarrow T; II \rightarrow P; III \rightarrow Q; IV \rightarrow R
 (C) I \rightarrow T; II \rightarrow R; III \rightarrow Q; IV \rightarrow P
 (D) I \rightarrow Q; II \rightarrow R; III \rightarrow S; IV \rightarrow P

Q17. LIST-I contains metal species and LIST-II contains their properties.

LIST-I	LIST-II
(I) $[\text{Cr}(\text{CN})_6]^{4-}$	(P) t_{2g} orbitals contain 4 electrons
(II) $[\text{RuCl}_6]^{2-}$	(Q) $\mu(\text{spin - only}) = 4.9\text{BM}$
(III) $[\text{Cr}(\text{H}_2\text{O}_6)]^{2+}$	(R) Low spin complex ion
(IV) $[\text{Fe}(\text{H}_2\text{O}_6)]^{2+}$	(S) Metal ion in 4+ oxidation state
	(T) d^4 species

[Given: Atomic number of Cr = 24, Ru = 44, Fe = 26]

Match each metal species in LIST-I with their properties in LIST-II, and choose the correct option

- (A) I \rightarrow R, T; II \rightarrow P, S; III \rightarrow Q, T; IV \rightarrow P, Q
 (B) I \rightarrow R, S; II \rightarrow P, T; III \rightarrow P, Q; IV \rightarrow Q, T
 (C) I \rightarrow P, R; II \rightarrow R, S; III \rightarrow R, T; IV \rightarrow P, T
 (D) I \rightarrow Q, T; II \rightarrow S, T; III \rightarrow P, T; IV \rightarrow Q, R

Q18. Match the compounds in LIST-I with the observations in LIST-II, and choose the correct option.

LIST-I	LIST-II
(I) Aniline	(P) Sodium fusion extract of the compound on boiling with FeSO_4 , followed by acidification with conc. H_2SO_4 , gives Prussian blue color.
(II) <i>o</i> -Cresol	(Q) Sodium fusion extract of the compound on treatment with sodium nitroprusside gives blood red color.
(III) Cysteine	(R) Addition of the compound to a saturated solution of NaHCO_3 results in effervescence.
(IV) Caprolactam	(S) The compound reacts with bromine water to give a white precipitate.
	(T) Treating the compound with neutral FeCl_3 solution produces violet color.

(A) I \rightarrow P, Q; II \rightarrow S; III \rightarrow Q, R; IV \rightarrow P
 (B) I \rightarrow P; II \rightarrow R, S; III \rightarrow R; IV \rightarrow Q, S
 (C) I \rightarrow Q, S; II \rightarrow P, T; III \rightarrow P; IV \rightarrow S
 (D) I \rightarrow P, S; II \rightarrow T; III \rightarrow Q, R; IV \rightarrow P

FIITJEE JEE (Advanced Paper)

(PAPER-1)

ANSWER KEY

MATHEMATICS

1.	2.35 or 2.36	2.	0.5	3.	0.80	4.	0.50
5.	4	6.	18900	7.	569	8.	0.83 or 0.84
9.	C, D	10.	B, C	11.	A, B, D	12.	A, B, C
13.	B, C, D	14.	A, C	15.	B	16.	A
17.	B	18.	C				

PHYSICS

1.	2.30	2.	2.32	3.	8.00	4.	6.00
5.	0.52	6.	2.85	7.	4.00	8.	0.95
9.	B	10.	A, B, C, D	11.	B	12.	A, B
13.	A, B, C	14.	A, B, D	15.	None	16.	C
17.	C	18.	A				

CHEMISTRY

1.	90.39	2.	0.77	3.	10.02	4.	0.32
5.	2.38	6.	1.50	7.	1.31	8.	136.00
9.	A, D	10.	A, D	11.	B, C, D	12.	A, D
13.	B, C, D	14.	A, B, C	15.	A	16.	D
17.	A	18.	D				

HINTS AND SOLUTIONS

MATHEMATICS

1. **2.35 or 2.36**

$$\text{Let } \tan \theta = \frac{\pi}{\sqrt{2}} \Rightarrow \frac{\pi}{4} \leq \theta \leq \frac{\pi}{2} \Rightarrow \pi = \sqrt{2} \tan \theta$$

$$\frac{3}{2} \cos^{-1} \sqrt{\frac{2}{2+2 \tan^2 \theta}} + \frac{1}{4} \sin^{-1} \left(\frac{2\sqrt{2}\sqrt{2} \tan \theta}{2+2 \tan^2 \theta} \right) + \tan^{-1} \left(\frac{\sqrt{2}}{\sqrt{2} \tan \theta} \right)$$

$$= \frac{3}{2} \cos^{-1}(\cos \theta) + \frac{1}{4} \sin^{-1}(\sin 2\theta) + \tan^{-1}(\cot \theta)$$

$$\frac{3}{2} \theta + \frac{1}{4}(\pi - 2\theta) + \frac{\pi}{2} - \theta = \frac{\pi}{4} + \frac{\pi}{2} = \frac{3\pi}{4}$$

2. **0.5**

$$\lim_{x \rightarrow \alpha^+} f(g(x)) = f\left(\lim_{x \rightarrow \alpha^+} g(x)\right)$$

$$\text{Now } \lim_{x \rightarrow \alpha^+} g(x) = \lim_{x \rightarrow \alpha^+} \frac{2 \ln(\sqrt{x} - \sqrt{\alpha})}{\ln(e^{\sqrt{x}} - e^{\sqrt{\alpha}})} \quad \left(\frac{-\infty}{-\infty} \right)$$

Apply D'L Hospital

$$\lim_{x \rightarrow \alpha^+} \frac{2 \cdot \frac{1}{\sqrt{x} - \sqrt{\alpha}} \cdot \frac{1}{2\sqrt{x}}}{\frac{1}{e^{\sqrt{x}} - e^{\sqrt{\alpha}}} \cdot e^{\sqrt{x}} \cdot \frac{1}{2\sqrt{x}}}$$

$$\lim_{x \rightarrow \alpha^+} \frac{2(e^{\sqrt{x}} - e^{\sqrt{\alpha}})}{e^{\sqrt{x}}(\sqrt{x} - \sqrt{\alpha})}$$

$$\lim_{x \rightarrow \alpha^+} \frac{2e^{\sqrt{\alpha}}(e^{\sqrt{x} - \sqrt{\alpha}} - 1)}{e^{\sqrt{x}}(\sqrt{x} - \sqrt{\alpha})} = 2$$

$$\text{Now } f(x) = \sin \frac{\pi x}{12} \text{ given}$$

$$f(2) = \sin \frac{\pi(2)}{12} = \sin \frac{\pi}{6} = \frac{1}{2} = 0.5$$

3. **0.80**

Let A denote the persons having symptoms of fever.
B denote the persons having symptoms of cough
C denote the persons having symptoms of breathing problem

Given that

$$n(A) = 190 \quad n(B) = 220 \quad n(C) = 220$$

$$n(A \cap B \cap C) = 30$$

$$n(A \cup B) = 330 \quad n(B \cup C) = 350 \quad n(C \cup A) = 340$$

$$n(A \cup B) = n(A) + n(B) - n(A \cap B)$$

$$\Rightarrow 330 = 190 + 220 - n(A \cap B) \Rightarrow n(A \cap B) = 80$$

$$\text{Similarly } n(B \cap C) = 90 \text{ and } n(C \cap A) = 70$$

If we make the Venn diagram

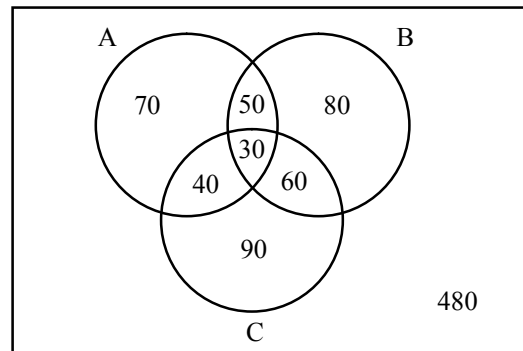

$$n(A \cup B \cup C) = n(A) + n(B) + n(C) - n(A \cap B) - n(B \cap C) - n(C \cap A) + n(A \cap B \cap C)$$

$$= 190 + 220 + 220 - 80 - 90 - 70 + 30 = 420$$

\therefore Number of person having atmost one symptom
 $= 480 + 70 + 80 + 90 = 720$

$$\therefore \text{Probability} = \frac{720}{900} = \frac{4}{5} = 0.80$$

4. **0.50**

$\frac{2+3z+4z^2}{2-3z+4z^2}$ is a real number

$$\Rightarrow 1 + \frac{6}{\frac{2}{z} - 3 + 4z} \in \mathbb{R} \Rightarrow 2z + \frac{1}{z} \in \mathbb{R} \Rightarrow 2z + \frac{1}{z} = 2\bar{z} + \frac{1}{\bar{z}}$$

$$\Rightarrow (2\bar{z} - 1)(z - \bar{z}) = 0$$

$$\Rightarrow |z|^2 = \frac{1}{2} = 0.50$$

5. **4**

Let $z = x + iy$

$$x - iy - x^2 + y^2 - 2ixy = i(x - iy + x^2 - y^2 + 2ixy)$$

$$(x - x^2 + y^2) - i(y + 2xy) = (y - 2xy) + i(x + x^2 - y^2)$$

$$\Rightarrow \begin{aligned} x - x^2 + y^2 &= y - 2xy & \dots(1) \\ x + x^2 - y^2 &= -y - 2xy & \dots(2) \end{aligned}$$

$$(1) + (2) \quad 2x = -4xy$$

$$\Rightarrow x = -2xy \Rightarrow x(1 + 2y) = 0 \Rightarrow x = 0 \text{ or } y = -\frac{1}{2}$$

Put $x = 0$ in (1) or (2) we get

$$y^2 = y \Rightarrow y = 0, 1$$

\therefore 2 complex numbers are possible $0 + 0i$ and $0 + i$

$$\text{put } y = -\frac{1}{2} \text{ in (1) or (2) } \quad x - x^2 + \frac{1}{4} = -\frac{1}{2} + x$$

$$\Rightarrow x^2 = \frac{3}{4} \Rightarrow x = \pm \frac{\sqrt{3}}{2}$$

$$\therefore \frac{\sqrt{3}}{2} - \frac{i}{2} \text{ and } -\frac{\sqrt{3}}{2} - \frac{i}{2} \text{ are possible}$$

\therefore 4 solutions are possible.

6. **18900**

$$A_{51} - A_{50} = 1000$$

$$l_{51}w_{51} - l_{50}w_{50} = 100$$

$$(l_1 + 50d_1)(w_1 + 50d_2) - (l_1 + 49d_1)(w_1 + 49d_2) = 1000$$

$$l_1w_1 + 50l_1d_2 + 50d_1w_1 + 2500d_1d_2 - l_1w_1 - 49l_1d_2 - 49d_1w_1 - 240d_1d_2 = 1000$$

$$\Rightarrow l_1d_2 + d_1w_1 + 99d_1d_2 = 1000$$

$$\Rightarrow l_1d_2 + d_1w_1 = 10$$

$$A_{100} - A_{90} = (l_{100}w_{100}) - (l_{90}w_{90})$$

$$= (l_1 + 99d_1)(w_1 + 99d_2) - (l_1 + 89d_1)(w_1 + 89d_2)$$

$$= 10d_1w_1 + 10l_1d_2 + 1880d_1d_2$$

$$= 10 \times 10 + 18800 = 18900$$

10. **B, C**

$$\sum_{n=1}^n (T_{n+1} - T_n) = \sum a_n$$

$$\Rightarrow T_{n+1} - T_1 = \sum a_n = \frac{n}{2} [2 \times 7 + (n-1)8]$$

$$T_{n+1} = n(4n+3) + T_1$$

$$T_{n+1} = 4n^2 + 3n + 3$$

$$(A) \quad T_{20} = 4 \times 19^2 + 3 \times 19 + 3 \\ = 1444 + 27 + 3 = 1474$$

$$(B) \quad \sum_{k=0}^{19} T_{k+1} = \sum_{k=0}^{19} k(4k+3) + 3 \\ = \sum_{k=0}^{19} (4k^2 + 3k + 3) = 10510$$

$$(C) \quad T_{30} = 29(4 \times 29 + 3) + 3 = 3454$$

$$(D) \quad \sum_{k=1}^{30} T_k = \sum_{n=0}^{29} T_{n+1} = \sum_{n=0}^{29} n(4n+3) + 3 \\ = 4 \times \left(\frac{29 \times 30 \times 59}{6} \right) + \frac{3(29 \times 30)}{2} + 90 = 35615$$

11. **A, B, D**

The line should be either coincident on P_1 or on P_2 or intersect on P_1 and P_2 on different points.

$$(D) \quad \frac{x}{1} = \frac{y-4}{-2} = \frac{z}{3} = \lambda$$

$$\Rightarrow (\lambda, -2\lambda + 4, 3\lambda) \text{ lie on } P_2$$

$$(A) \quad \frac{x-1}{0} = \frac{y-1}{0} = \frac{z-1}{5} \text{ intersects } P_1 \text{ and } P_2 \text{ on different points.}$$

$$(B) \quad \frac{x-6}{5} = \frac{y}{2} = \frac{z}{3} \text{ also intersects } P_1 \text{ and } P_2 \text{ on different points.}$$

12. **A, B, C**

Clearly plane is given by $x + y + z = 1$
using mirror image formula

$$\Rightarrow \frac{\alpha-10}{1} = \frac{\beta-15}{1} = \frac{\gamma-20}{1} = \frac{-2(10+15+20-1)}{1^2+1^2+1^2} = -\frac{88}{3}$$

$$\Rightarrow \alpha = -\frac{58}{3}; \beta = -\frac{43}{3} \text{ and } \gamma = -\frac{28}{3}$$

13. **B, C, D**

Let P_1 and P_2 be $(t_1^2, 2t_1)$ and $(t_2^2, 2t_2)$

$$\Rightarrow P \equiv (t_1 t_2, t_1 + t_2) \equiv (-2, 1)$$

$$\Rightarrow t_1 = 2, t_2 = -1 \text{ or } t_1 = -1, t_2 = 2$$

$$\Rightarrow P_1(4, 4) \text{ and } P_2(1, -2)$$

$$\text{Slope of } SP_1 = \frac{4}{3} \text{ slope of } SP_2 = \infty$$

Equation of SP_1

$$y - 0 = \frac{4}{3}(x - 1) \Rightarrow 4x - 3y - 4 = 0$$

Equation of PQ_1

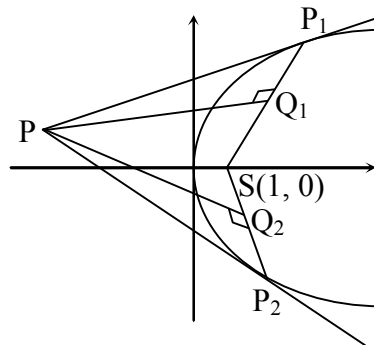

$$y - 1 = -\frac{4}{3}(x + 2) \Rightarrow 3x + 4y + 2 = 0 \therefore Q_1\left(\frac{2}{5}, -\frac{4}{5}\right)$$

$$\text{Equation of } SP_2 \quad x = 1$$

$$\text{Equation of } PQ_2 \quad y = 1 \therefore Q_2(1, 1)$$

$$\therefore SQ_1 = 1, Q_1Q_2 = \frac{3\sqrt{10}}{5}$$

$$PQ_1 = \sqrt{\left(-2 - \frac{2}{5}\right)^2 + \left(1 + \frac{4}{5}\right)^2} = \sqrt{\frac{144}{25} + \frac{81}{25}} = 3$$

$$\text{and } SQ_2 = \sqrt{(1-1)^2 + (1-0)^2} = 1$$

14. **A, C**

$$f(\theta) = \frac{1}{2} \begin{vmatrix} 0 & 0 & 2 \\ -\sin\theta & 1 & \sin\theta \\ -1 & -\sin\theta & 1 \end{vmatrix} + \begin{vmatrix} \sin\pi & \cos\left(\theta + \frac{\pi}{4}\right) & \tan\left(\theta - \frac{\pi}{4}\right) \\ \sin\left(\theta - \frac{\pi}{4}\right) & -\cos\frac{\pi}{2} & \log_e\left(\frac{4}{\pi}\right) \\ \cot\left(\theta + \frac{\pi}{4}\right) & \log_e\left(\frac{\pi}{4}\right) & \tan\pi \end{vmatrix}$$

As second determinant is skew symmetric \therefore its value is 0.

$$\Rightarrow f(\theta) = (1 + \sin^2\theta)$$

$$\Rightarrow g(\theta) = |\sin\theta| + |\cos\theta| \in [1, \sqrt{2}]$$

$$\Rightarrow p(x) = a(x-1)(x-\sqrt{2}) \text{ as } p(2) = 2 - \sqrt{2} \Rightarrow a = 1$$

$$\Rightarrow p(x) = (x-1)(x-\sqrt{2})$$

$$\text{and hence } p\left(\frac{3+\sqrt{2}}{4}\right) < 0 \text{ and } p\left(\frac{5\sqrt{2}-1}{4}\right) > 0$$

15. **B**

(I) $\cos x + \sin x = 1$

$$\Rightarrow \sqrt{2} \cos\left(x - \frac{\pi}{4}\right) = 1$$

$$\Rightarrow \cos\left(x - \frac{\pi}{4}\right) = \frac{1}{\sqrt{2}}$$

$$\Rightarrow x - \frac{\pi}{4} = 2n\pi \pm \frac{\pi}{4}$$

$$\text{for } n = 0, x = \frac{\pi}{2}, 0$$

$$\text{for } n = 1, 2, 3, \dots \text{ no solution in } \left[-\frac{2\pi}{3}, \frac{2\pi}{3}\right] \therefore I \rightarrow P$$

(II) $\tan 3x = \frac{1}{\sqrt{3}} \Rightarrow 3x = n\pi + \frac{\pi}{6} \Rightarrow x = \frac{n\pi}{3} + \frac{\pi}{18}$

$$\text{for } n = 0 \quad x = \frac{\pi}{18} \quad \text{for } n = -1, x = -\frac{5\pi}{18}$$

$$\text{for } n = 1, 2, 3, \dots \text{ no solution } \therefore II \rightarrow P$$

$$(III) \quad \cos 2x = \frac{\sqrt{3}}{2} \Rightarrow 2x = 2n\pi \pm \frac{\pi}{6} \Rightarrow x = n\pi \pm \frac{\pi}{12}$$

$$\text{for } n = -1 \quad x = -\frac{13\pi}{12}, -\frac{11\pi}{12} \therefore III \rightarrow T$$

$$(IV) \quad \cos\left(\frac{\pi}{4} + x\right) = -\frac{1}{\sqrt{2}} \Rightarrow x + \frac{\pi}{4} = 2n\pi \pm \frac{3\pi}{4}$$

$$\text{for } n = 0 \quad x = \frac{\pi}{2}, -\pi$$

$$\text{for } n = 1 \quad x = \pi \quad \text{for } n = -1 \quad x = -\frac{3\pi}{2} \therefore IV \rightarrow R$$

16. **A**

$$\text{Let } A_1 ; P_1 \text{ won the round} \Rightarrow P(A_1) = \frac{{}^6C_2}{6^2} = \frac{6 \times 5}{2 \times 6 \times 6}$$

$$P(A_1) = \frac{5}{12}$$

$$A_2 ; P_2 \text{ won the round} \Rightarrow P(A_2) = \frac{5}{12}$$

$$D ; \text{round ends in draw} \Rightarrow P(D) = \frac{6}{6^2} = \frac{1}{6}$$

$$(i) \quad P(X_2 \geq Y_2) = P(A_1 \cap A_1) + 2P(A_1 \cap A_2) + P(D \cap D) + 2P(A_1 \cap D)$$

$$= \frac{5}{12} \cdot \frac{5}{12} + 2 \cdot \frac{5}{12} \cdot \frac{5}{12} + \frac{1}{6} \cdot \frac{1}{6} + 2 \cdot \frac{5}{12} \cdot \frac{1}{6} = \frac{11}{16}$$

$$\Rightarrow (1) \rightarrow (Q)$$

$$(ii) \quad P(X_2 > Y_2) = P(A_1 \cap A_1) + 2P(A_1 \cap D)$$

$$= \frac{5 \times 5}{12 \times 12} + 2 \cdot \frac{5}{12} \cdot \frac{1}{6} = \frac{25}{144} + \frac{5}{36} = \frac{45}{144} = \frac{5}{16}$$

$$\Rightarrow (ii) \rightarrow R$$

$$(iii) \quad P(X_3 = Y_3) = 3P(A_1 \cap D \cap A_2) + P(D \cap D \cap D)$$

$$= 6 \times \frac{5}{12} \times \frac{5}{12} \times \frac{1}{6} + \frac{1}{6} \times \frac{1}{6} \times \frac{1}{6}$$

$$= \frac{25}{144} + \frac{1}{216} = \frac{75+2}{432} = \frac{77}{432}$$

$$\Rightarrow (iii) \rightarrow T$$

$$(iv) \quad P(X_3 > Y_3) = P(A_1 \cap A_1 \cap A_1) + 3P(A_1 \cap A_1 \cap A_2) + 3P((A_1 \cap A_1 \cap D) + 3P(A_1 \cap D \cap D))$$

$$= \frac{5}{12} \times \frac{5}{12} \times \frac{5}{12} + 3 \times \frac{5}{12} \times \frac{5}{12} \times \frac{5}{12} + 3 \times \frac{5}{12} \times \frac{5}{12} \times \frac{1}{6} + 3 \times \frac{5}{12} \times \frac{1}{6} \times \frac{1}{6}$$

$$= \frac{710}{12^3} = \frac{355}{144 \times 6} = \frac{355}{864}$$

$$\therefore IV \rightarrow S$$

17. **B**

$$x + y + z = 1 \quad \dots (1)$$

$$10x + 100y + 1000z = 0 \quad \dots (2)$$

$$\frac{x}{p} + \frac{y}{q} + \frac{z}{r} = 0 \quad \dots (3)$$

$$\frac{1}{p} = A + 9d ; \frac{1}{q} = A + 99d ; \frac{1}{r} = A + 999d$$

⇒ From equation (2) and (3), we get $(A - d)x + (A - d)y + (A - d)z = 0$

⇒ If $A \neq d$, then no solution

If $A = d \Rightarrow \frac{p}{q} = 10, \frac{q}{r} = 10, \frac{p}{r} = 100$ then the equations have infinite solutions

Now, equation (2) and (3) both are same

So, (1) and (2) both equation are satisfying $x = 0, y = \frac{10}{9}, z = \frac{-1}{9}$

18.

C

Equation of auxiliary circle $x^2 + y^2 = 4$

∴ Let F be $(2 \cos \theta, 2 \sin \theta)$

∴ E is $(2 \cos \theta, \sqrt{3} \sin \theta)$

Equation of tangent at E, $\frac{x \cos \theta}{2} + \frac{y \sin \theta}{\sqrt{3}} = 1$

It cuts x-axis at $(2 \sec \theta, 0)$

∴ G is $(2 \sec \theta, 0)$

H is $(2 \cos \theta, 0)$ and F $(2 \cos \theta, 2 \sin \theta)$

∴ Area of ΔFGH is $\frac{1}{2} \times 2 \sin \theta (2 \sec \theta - 2 \cos \theta)$

$= 2 \sin \theta (\sec \theta - \cos \theta)$

If $\theta = \frac{\pi}{4}$, area $= 2 \times \frac{1}{\sqrt{2}} \left(\sqrt{2} - \frac{1}{\sqrt{2}} \right) = 1$

If $\theta = \frac{\pi}{3}$, area $= 2 \times \frac{\sqrt{3}}{2} \left(2 - \frac{1}{2} \right) = \frac{3\sqrt{3}}{2}$

If $\theta = \frac{\pi}{6}$, area $= 2 \times \frac{1}{2} \left(\frac{2}{\sqrt{3}} - \frac{\sqrt{3}}{2} \right) = \frac{1}{2\sqrt{3}}$

If $\theta = \frac{\pi}{12}$, area $= 2 \times \frac{\sqrt{3}-1}{2\sqrt{2}} \left(\frac{2\sqrt{2}}{\sqrt{3}+1} - \frac{\sqrt{3}+1}{2\sqrt{2}} \right) = \left(\frac{\sqrt{3}-1}{8} \right)^4$

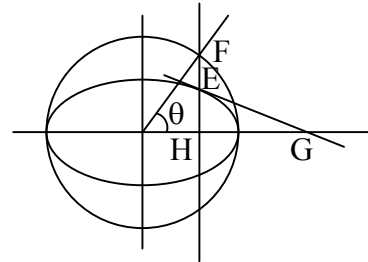

PHYSICS

1. 2.30

$$M_B = 2M_A \quad \Rightarrow \quad \rho_B = 2\rho_A$$

Now after the mass transfer,

$$M'_A = \rho_A \frac{4}{3} \times \frac{R^3}{8} \quad \text{and} \quad M'_B = G \frac{4}{3} \pi \left(2\rho_A R^3 + \frac{7}{8} \rho_A R^3 \right)$$

$$\text{and outer radius } R' = \frac{(15)^{1/3}}{2} R$$

$$\text{So, } v_A = \sqrt{\frac{2GM'_A}{R}} = \sqrt{\frac{2}{3} G \rho_A \pi R^2}$$

$$v_B = \sqrt{\frac{2G(4/3)\pi(2\rho_A R^3 + \frac{7}{8}\rho_A R^3)}{R'}}$$

$$\frac{v_B}{v_A} = \sqrt{\frac{23}{(15)^{1/3}}} = \sqrt{\frac{(2.3)(10)}{(15)^{1/3}}}$$

So, $n = 2.30$

2. **2.32**

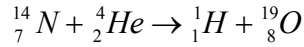

$$Q = [16.006 + 4.003 - 1.008 - 19.003] \times 930$$

$$= -1.86 \text{ MeV}$$

$$E_{\text{th}} = \left(1 + \frac{m}{M}\right) |Q| \approx \left(1 + \frac{4}{16}\right) (1.86) = 2.32 \text{ MeV}$$

3. **8.00**

In the loop 1234, $+6 - \frac{48}{12} - \frac{q_3}{4} = 0$, $q_1 = 12(6 - 2) = 48 \mu\text{C}$

$$q_3 = 8 \mu\text{C}$$

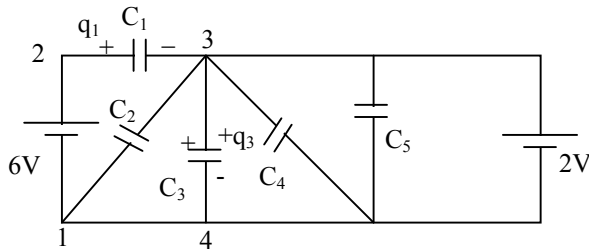

4. **6.00**

$$u_1 = -\frac{40}{3}$$

$$f = 10$$

$$\frac{1}{V_1} + \frac{1 \times 3}{40} = \frac{1}{10}$$

$$V_1 = 40$$

$$u_2 = -\frac{43}{3}$$

$$\frac{1}{V_2} = \frac{1}{10} - \frac{3}{43} = \frac{43 - 30}{430}$$

$$V_2 = \frac{430}{13}$$

$$x_2 = V_1 - V_2 = 40 - \frac{430}{13} = \frac{90}{13}$$

$$\tan \alpha = \frac{30\sqrt{3}}{13 \times x} = \frac{30\sqrt{3} \times 13}{13 \times 90} = \frac{1}{\sqrt{3}}$$

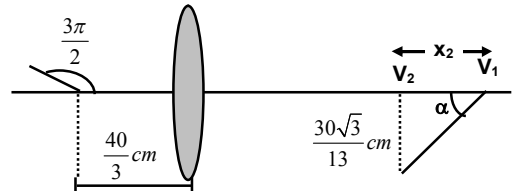

$$\alpha = \frac{\pi}{6} = \frac{\pi}{n}$$

$$n = 6$$

5. **0.52**

$$\theta = \frac{1}{2} \alpha t^2$$

$$= \frac{1}{2} \times \frac{2}{3} \pi = \frac{\pi}{3} = 60^\circ$$

$$v_{cm} = \alpha t$$

Net velocity of point P is $V = \alpha t$ at an angle 60° with horizontal

$$u_y = \alpha t \sin 60^\circ$$

$$y_{\max} = \frac{1}{2} + \frac{u_y^2}{2g} = \frac{1}{2} + \frac{\alpha^2 t^2}{20} \cdot \frac{3}{4} = \frac{1}{2} + \frac{\pi}{60}$$

$$x = 0.52$$

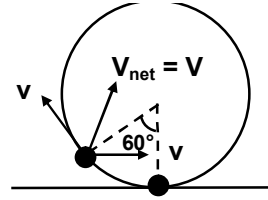
6. **2.85**

$$mg \sin \theta \times R + 1 \times \frac{R}{2} - 1 \times \frac{3R}{2} = I_P \alpha$$

$$\frac{10}{2} \times 1 + \frac{1}{2} - \frac{3}{2} = \frac{7}{5} \times mR^2 \alpha$$

$$5 - 1 = \frac{7}{3} \alpha$$

$$\frac{20}{7} = \alpha$$

$$a_{cm} = R\alpha = \frac{20}{7}$$

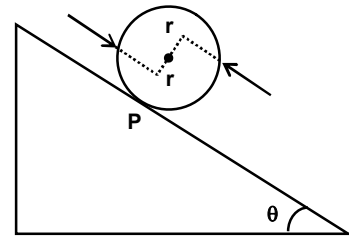
7. **4.00**

$$\phi = (B_0 + \beta t)A$$

$$|\varepsilon_{\text{ind}}| = \frac{d\phi}{dt} = \beta A$$

Applying KVL in the equivalent circuit diagram of the loop.

$$\beta A - \frac{L di}{dt} - \frac{q}{C} = 0 \quad \dots (i)$$

$$\text{Also, } i = \frac{dq}{dt} \quad \dots (ii)$$

$$\text{From (i) and (ii) } L \frac{d^2 i}{dt^2} = -\frac{i}{c}$$

$$i = i_m \sin \omega t \quad \omega = \frac{1}{\sqrt{LC}}$$

$$\int_0^q dq = i_m \int_0^t \sin(\omega t) dt$$

$$q = \frac{i_m}{\omega} (1 - \cos \omega t)$$

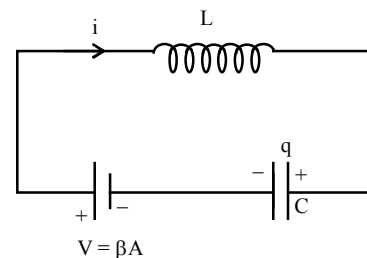

when $i = i_m \Rightarrow \sin \omega t = 1 \Rightarrow \cos \omega t = 0$

$$q = \frac{i_m}{\omega} = \beta AC$$

$$I_m = \omega \beta AC = \beta A \sqrt{\frac{C}{L}} = 4mA$$

8. **0.95**

$$d' = \frac{d}{2} + \sqrt{\frac{2H}{g'}} v \cos \theta = \frac{d}{2} + \sqrt{\frac{2}{g'} \frac{v^2 \sin^2 \theta}{2g}} v \cos \theta$$

$$d' = \frac{d}{2} + \frac{V^2 \sin \theta \cos \theta}{\sqrt{g \frac{g}{0.81}}} = \frac{d}{2} + \frac{d \left(\frac{9}{10} \right)}{20} = \frac{19d}{20}$$

$$d' = 0.95d$$

$$n = 0.95$$

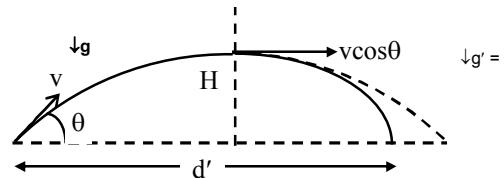
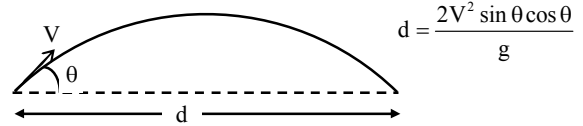

9. **B**

Refer to figure (a)

$$V = E_1 d$$

$$C_1 = \frac{k \epsilon_0 A}{d}$$

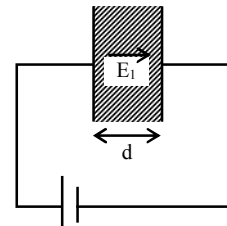

Figure(a)

Refer to figure (b)

$$V = E_3 \frac{d}{2} + E_2 \frac{d}{2} + E_3 \frac{d}{2}$$

$$\text{Also } E_3 = E_2 K$$

$$V = E_2 d + K E_2 d$$

$$V = (K + 1) E_2 d$$

$$C_2 = \frac{\epsilon_0 A}{d + \frac{d}{K}} = \frac{K \epsilon_0 A}{K + 1} \frac{1}{d}$$

$$\text{Now } \frac{E_1}{E_2} = K + 1$$

$$\frac{C_1}{C_2} = (K + 1)$$

$$W_{\text{ext}} + W_{\text{battery}} = \Delta U$$

$$W_{\text{ext}} + (C_2 - C_1) V^2 = (C_2 - C_1) \frac{V^2}{2}$$

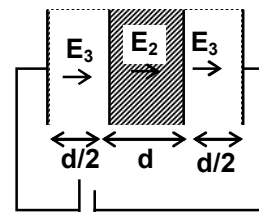

Figure(b)

$$W_{\text{ext}} = (C_1 - C_2) \frac{V^2}{2} = \frac{K\epsilon_0 A}{d} \left(1 - \frac{1}{K+1}\right) \frac{V^2}{2} = \frac{K^2 \epsilon_0 A V^2}{2d(K+1)}$$

10. **A, B, C, D**

$$-(i - i_1) + 6 - \frac{1}{2}(i - i_1) + \frac{1}{2}i_1 = 0$$

$$-\frac{3}{2}(i - i_1) + \frac{i_1}{2} + 6 = 0$$

$$-\frac{3}{2}i + \frac{3}{2}i_1 + \frac{i_1}{2} + 6 = 0$$

$$-\frac{3}{2}i + 2i_1 + 6 = 0$$

$$-\frac{i_1}{2} - \frac{i}{2} - i + 12 = 0$$

$$-\frac{i_1}{2} - \frac{3}{2}i + 12 = 0$$

$$\frac{5}{2}i_1 - 6 = 0$$

$$i_1 = \frac{6 \times 2}{5} = \frac{12}{5} = 2.4$$

$$-1.2 - 1.5i + 12 = 0$$

$$1.5i = 10.8$$

$$i = \frac{10.8}{1.5}$$

$$i = 7.2$$

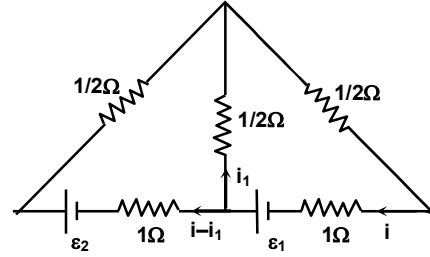

11. **B**

$$P^{1-\gamma} T^\gamma = \text{Const.}$$

$$P_2 = 150 \text{ Pa} \quad \dots(1)$$

$$\frac{dm}{dt} = \rho_1 A_1 v_1$$

$$v_1 = 40 \text{ m/s} \quad \dots(2)$$

$$\rho = \frac{PM}{RT}$$

$$\rho_2 = 0.1 \text{ Kg/m}^3 \quad \dots(3)$$

$$\rho_1 A_1 v_1 = \rho_2 A_2 v_2$$

$$v_2 = 20 \text{ m/s} \quad \dots(4)$$

From work energy theorem,

$$P_1 A_1 v_1 dt - \rho_2 A_2 v_2 dt + \rho_1 A_1 v_1 dt g(0) - \rho_2 A_2 v_2 dt g(h)$$

$$= \frac{1}{2} \rho_2 A_2 v_2 dt v_2^2 - \frac{1}{2} \rho_1 A_1 v_1 dt v_1^2 + \frac{1}{\gamma - 1} [P_2 A_2 v_2 dt - P_1 A_1 v_1 dt]$$

$$h = 360 \text{ m.}$$

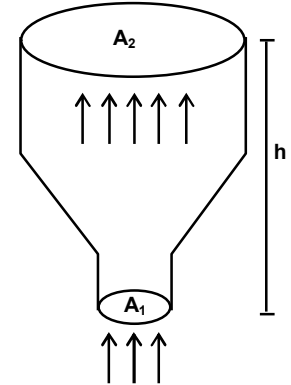

$$v_{\text{rel}} = | |\vec{v}_2 - \vec{v}_1 | = \sqrt{25\pi^2 + 1}$$

17.

C

$$W = P\Delta V = 0.1 \text{ kJ}$$

$$Q = mL = 2.25 \text{ kJ}$$

$$\Delta U = Q - W = 2.15 \text{ kJ}$$

$$\Rightarrow \frac{V}{500} = \frac{3V}{T} \Rightarrow T = 1500$$

$$\Delta U = nC_v \Delta T = 4 \text{ kJ}$$

$$\Rightarrow W = \frac{PV - (32P)(V/8)}{1 - 5/3} = 3 \quad [PV = P'(V/8)^{\gamma}; P' = 32 P]$$

$$\Rightarrow \frac{\Delta U}{\Delta Q} = \frac{nC_v \Delta T}{nC_p \Delta T} = \frac{1}{\nu} \quad (\nu = 6 - \text{vibration included})$$

$$\Delta U = 9 \times (3/4) \approx 7$$

18.

A

$$\frac{1}{v} = \frac{1}{f} + \frac{1}{u} \quad (\text{concave lens})$$

$$\Rightarrow v = -10$$

$$\frac{1}{v} = \frac{1}{f} + \frac{1}{u} \quad (\text{convex lens})$$

$$\frac{1}{v} = \frac{1}{10} + \frac{1}{-15}$$

$$\Rightarrow v = +30$$

CHEMISTRY

1.

$$\Delta T = 312.8 - 298 = 14.8$$

Molar heat capacity of calorimeter = 20 kJ K⁻¹

Heat released by combustion of 2 moles of Hg(g)

$$= -20 \times 14.8$$

$$= -296 \text{ kJ}$$

$$\Delta U_{\text{combustion}} = -\frac{296}{2} = -148 \text{ kJ mol}^{-1}$$

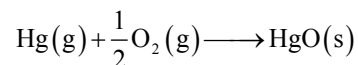

$$\Delta n_g = 0 - \left(1 + \frac{1}{2}\right) = -\frac{3}{2}$$

$$\Delta H_{\text{combustion}} = \Delta U_{\text{combustion}} + \Delta n_g RT$$

$$= -148 + \left(-\frac{3}{2}\right) \times 8.3 \times 10^{-3} \times 298$$

$$= -148 - 3.710$$

$$= -151.710 \text{ kJ mol}^{-1}$$

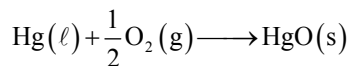

$$\Delta H_{\text{combustion}}^{\circ} = \Delta H_{\text{f}}^{\circ}(\text{HgO}) - \Delta H_{\text{Hg}(\ell) \rightarrow \text{Hg}(\text{g})}^{\circ} + \frac{1}{2}\Delta H_{\text{f}}^{\circ}\text{O}_2$$

$$-151.710 = \Delta H_{\text{f}}^{\circ}(\text{HgO}) - 61.32 + 0$$

$$\Delta H_{\text{f}}^{\circ}(\text{HgO}) = -151.710 + 61.32 = 90.39$$

$$\Delta H_{\text{f}}^{\circ} = \mathbf{90.39}$$

2. (i) $\text{MnO}_4^{-}(\text{aq}) + 8\text{H}^{+} + 7\text{e}^{-} \longrightarrow \text{Mn}(\text{s}) + 4\text{H}_2\text{O}(\ell)$; $\Delta G_1^{\circ} = -7 \times F \times E_1^{\circ}$
 (ii) $\text{MnO}_4^{-} + 4\text{H}^{+} + 3\text{e}^{-} \longrightarrow \text{MnO}_2(\text{s}) + 2\text{H}_2\text{O}(\ell)$; $\Delta G_2^{\circ} = -3 \times F \times 1.68$
 (iii) $\text{MnO}_2(\text{s}) + 4\text{H}^{+} + 2\text{e}^{-} \longrightarrow \text{Mn}^{2+}(\text{aq}) + 2\text{H}_2\text{O}(\ell)$; $\Delta G_3^{\circ} = -2 \times F \times 1.21$
 (iv) $\text{Mn}^{2+}(\text{aq}) + 2\text{e}^{-} \longrightarrow \text{Mn}(\text{s})$; $\Delta G_4^{\circ} = -2 \times F \times (-1.03)$

Now,

$$(i) = (ii) + (iii) + (iv)$$

$$\Delta G_1^{\circ} = \Delta G_2^{\circ} + \Delta G_3^{\circ} + \Delta G_4^{\circ}$$

$$-7 \times F \times E_1^{\circ} = -3 \times F \times 1.68 - 2 \times F \times 1.21 + 2 \times F \times 1.03$$

$$-7E_1^{\circ} = 3 \times 1.68 + 2 \times 1.21 - 2 \times 1.03$$

$$E_1^{\circ} = \frac{3 \times 1.68 + 2 \times 1.21 - 2 \times 1.03}{7}$$

$$E_1^{\circ} = \frac{5.04 + 2.42 - 2.06}{7}$$

$$= 0.7714$$

$$= \mathbf{0.77 \text{ V}}$$

3.
$$\text{H}_2\text{CO}_3 + \text{NaOH} \longrightarrow \text{NaHCO}_3 + \text{H}_2\text{O}$$
- | | | | |
|----------------------|------|------|-------------|
| Initial mol | 0.01 | 0.01 | 0.01 |
| After neutralization | 0 | 0 | 0.01 + 0.01 |
| | | | = 0.02 |

Now, mixture contains 0.01 mole Na_2CO_3 and 0.02 mol of NaHCO_3 so it is a buffer.

$$\text{pH} = \text{pK}_{\text{a}_2} + \log \frac{[\text{CO}_3^{2-}]}{[\text{HCO}_3^{-}]}$$

$$\text{pH} = 10.32 + \log \frac{0.01}{0.02}$$

$$= 10.32 + \log \frac{1}{2}$$

$$= 10.32 - 0.30$$

$$= 10.02$$

4.
$$2\text{Cu}(\text{NO}_3)_2 + 4\text{KI} \longrightarrow 2\text{CuI} \downarrow + \text{I}_2 + 4\text{KNO}_3$$
- $$\text{I}_2 + \text{KI} \longrightarrow \text{KI}_3$$
-
- $$2\text{Cu}(\text{NO}_3)_2 + 5\text{KI} \longrightarrow 2\text{CuI} \downarrow + \text{KI}_3 + 4\text{KNO}_3$$
- $$\text{Mole} = \frac{3.74}{187} = 0.02 \qquad \frac{0.02}{2} = 0.01$$

8.

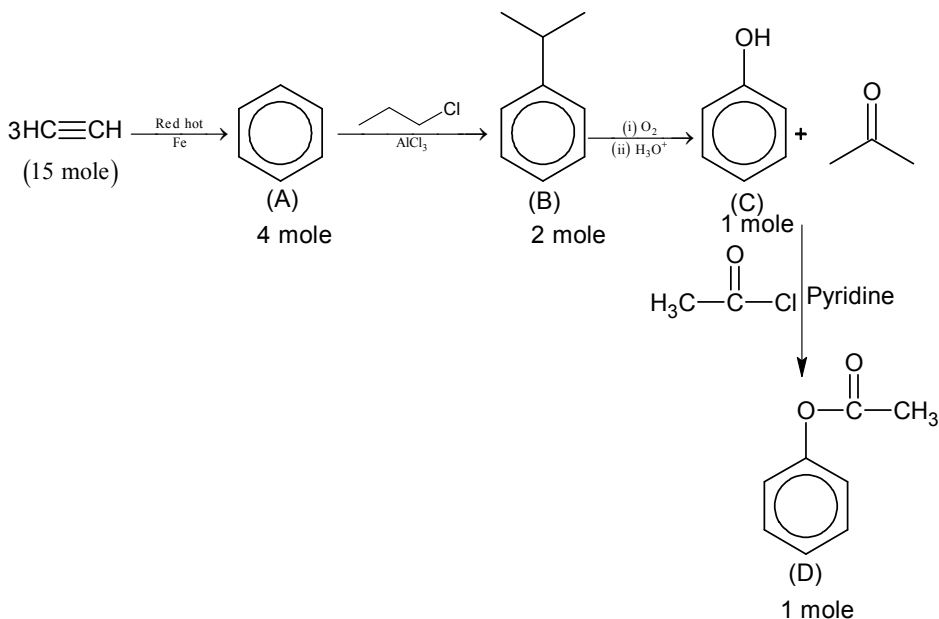

Molecular weight = $\text{C}_8\text{H}_8\text{O}_2$
 $= 12 \times 8 + 1 \times 8 + 16 \times 2 = 96 + 8 + 32 = 136$

Moles of product (D) formed

$= \frac{15}{3} \times 0.8 \times 0.5 \times 0.5 = \frac{3}{3} = 1 \therefore$ Weight of product (D) = $1 \times 136 = 136 \text{ g}$

9.

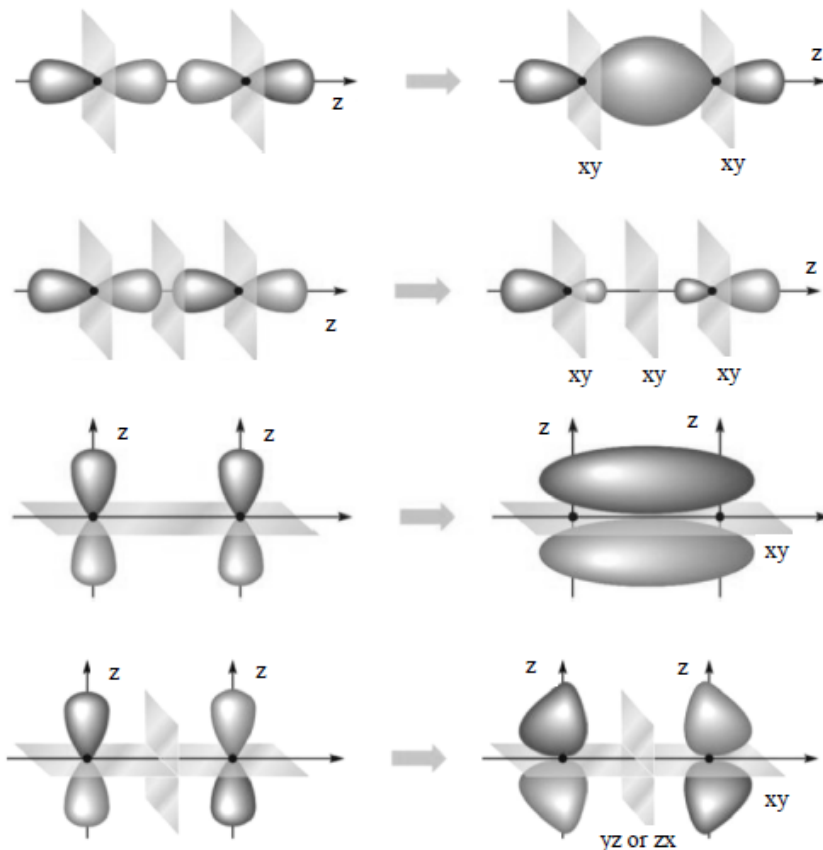

10. → Chemisorption is unimolecular layer and exothermic.
 → The enthalpy change in physisorption is 20 – 40 kJ/mol.
 → Physisorption decreases with increase of temperature.

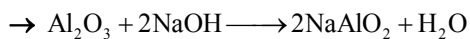
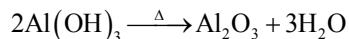
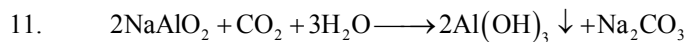

→ During electrolysis of alumina, cryolite (Na_3AlF_6) and fluorspar (CaF_2) are added to decrease the melting point of alumina.

→ Al metal is obtained at cathode while CO_2 releases at anode.

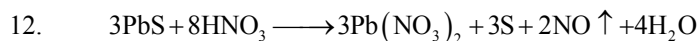

$\text{NO} \rightarrow$ paramagnetic, neutral oxide and colourless gas

13.

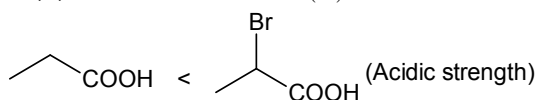
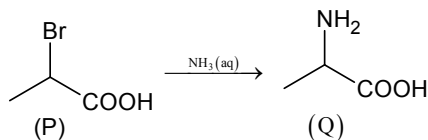
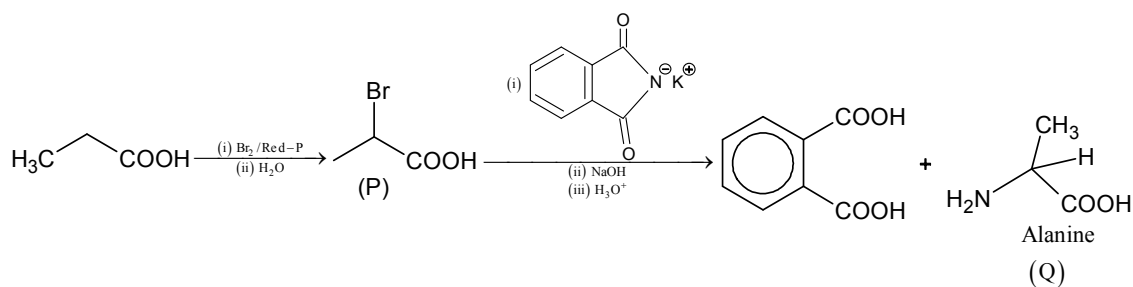

14.

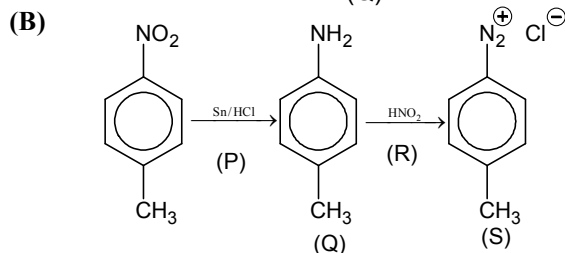
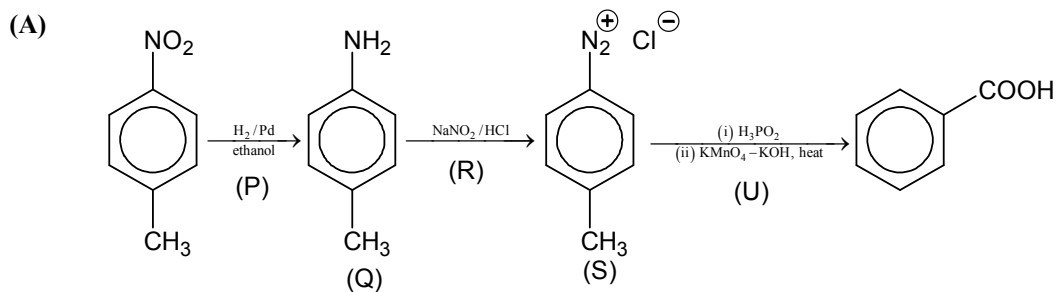

(C)

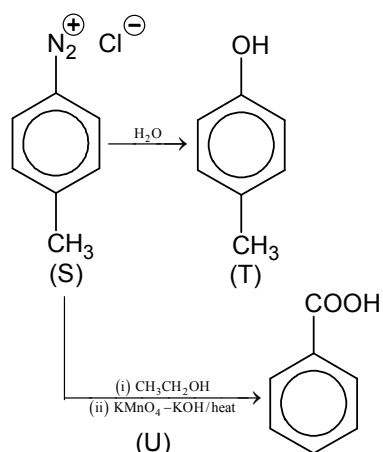

$$15. \quad \text{I} \rightarrow \text{Rate} = \frac{k[X]}{X_s + [X]}$$

If $[X]$ is low, then it follows first order kinetic i.e. $t_{1/2}$ is constant (OA part in graph)

If $[X]$ is high, then it follows zero order kinetics. So half life ($t_{1/2}$) varies linearly with $[X]$ as shown in graph.

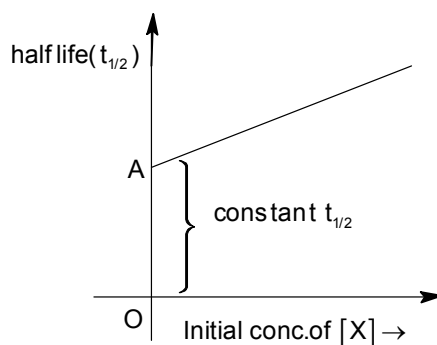

I \rightarrow P

$$\text{II} \rightarrow \text{Rate} = \frac{k[X]}{X_s + [X]}$$

If $[X]$ is less than X_s , then reaction follows Ist order kinetics as shown by the graph Q and T
 II \rightarrow Q, T

$$\text{III} \rightarrow \text{Rate} = \frac{k[X]}{X_s + [X]}$$

If $[X] \gg X_s$, then reaction follows zero order kinetics, as show by the graph (S)
 III \rightarrow S

$$\text{IV} \rightarrow \text{Rate} = \frac{k[X]^2}{X_s + [X]}$$

If $[X] \gg [X_s]$, then reaction follows first order kinetics, as show by the graph (Q), (T)
 IV \rightarrow Q, T

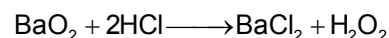
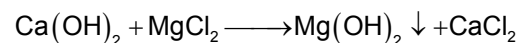
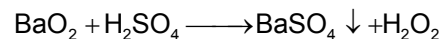
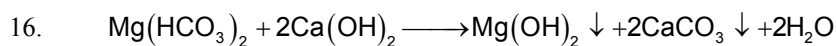

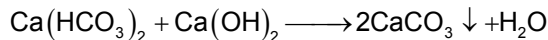

I → Q, S; II → P, R; III → S; IV → P, T

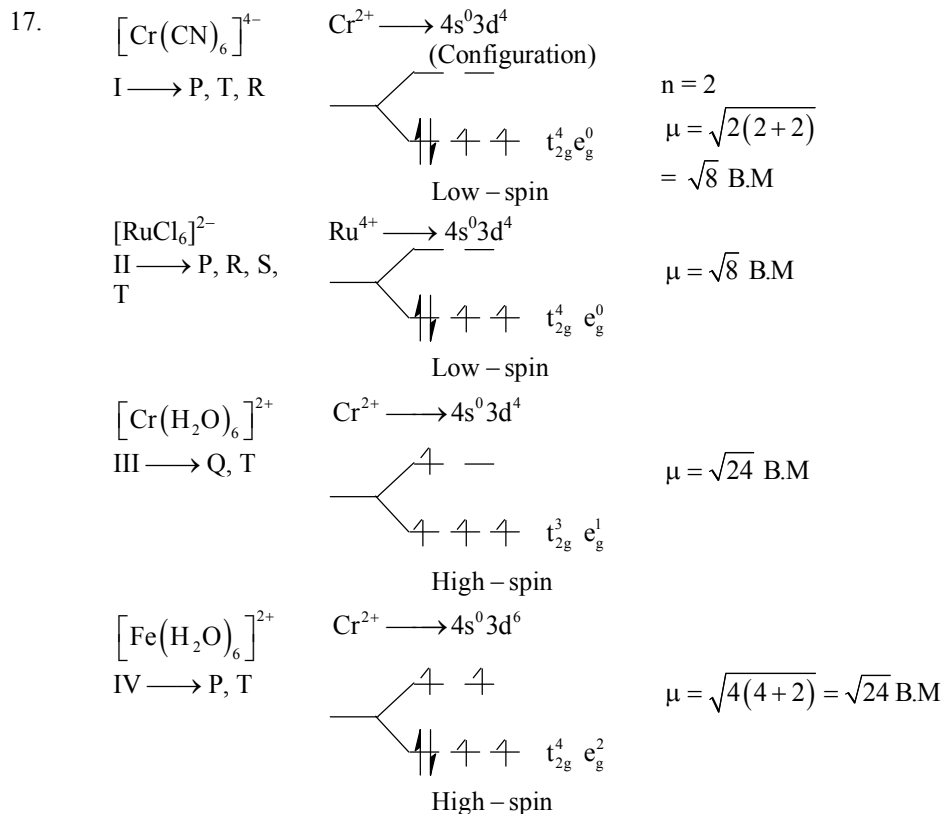

18. (I) since aniline contains C and N so its sodium extract will give Prussian Blue colour with $\text{FeSO}_4/\text{Conc. H}_2\text{SO}_4$

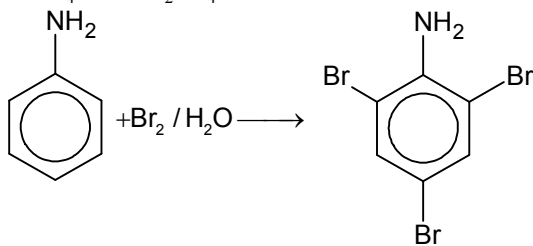

white ppt

(II) Produces violet colour with neutral FeCl_3

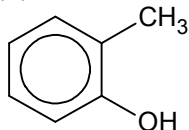

(III) It contains $-\text{COOH}$, so it give effervescence with NaHCO_3

It also contains C, N, S, so its Na-extract will give blood red colour with $\text{FeCl}_3/\text{H}_2\text{SO}_4$.

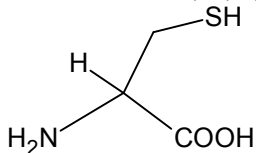

(IV) Caprolectum, it contains C and N, so its sodium extract will give Prussian blue colour

